

# Controlling for High Voltage Circuit Breakers by using mechanical operation of PMSM

Choppala Anil, Tappeta Amar Kiran

Department of EEE, Godavari Institute of Engineering & Technology (A), Rajahmundry, Andhra Pradesh, India.

**Abstract :** In this paper, a new type of motor drive operating mechanism of High Voltage Circuit Breakers (HVCB) based on techniques of power electronics and motor digital control has been studied. In this paper, the structure and the moving principle of operating mechanism for HVCB is analyzed and the control strategy for PMSM drive operating mechanism is described. The simulations, calculations and actual tests all indicate that parameters of the drive-motor such as the rotational inertia, the output torque and the output power will have impact on the performance of the operating mechanism. The research work of this paper has shown that it is advisable to adopt motor for driving operating mechanism of HVCB and such mechanism can meet the requirements for opening and closing operation of HVCBs.

**Key Words:** High-voltage circuit breaker, motor drive, operation mechanism, permanent-magnet synchronous motor.

## I. INTRODUCTION

High Voltage Circuit-Breakers (HVCBs) are the very important apparatus responsible for controlling and protection in the electric power systems. The operating mechanism is the basic device which controls the opening and closing operations of HVCB. At present, there are several conventional types of operating mechanisms, such as electromagnetic mechanisms, spring mechanisms, pneumatic mechanisms and hydraulic mechanisms. Even though those conventional mechanisms have many prominent merits, they also have some insurmountable limitations. They usually have complex structures which are difficult to adjust. Therefore periodic check-ups are necessary and costs for operation and maintenance are high. Additionally, with those conventional mechanisms, the process of opening and closing operations could not be controlled [1] [2].

In order to overcome the limitations of conventional operating mechanisms and improve the operation performance of HVCBs, it is necessary to do research on new techniques for operating mechanisms of HVCBs [3-5]. In this paper, a new type of motor drive operating mechanism of HVCB has been studied there is only one rotational part of an electric machine rotor in the motor-drive mechanism, which is compact in structure than conventional mechanisms [6]. In this motor-drive mechanism, capacitor bank is adopted to store the energy for controlling the operating mechanism instead of springs or compressed air [7]. The energy flows out of the capacitor bank, through the converter made up of power electronics device and drives the PMSM Under the control of Digital Signal Processor (DSP), the PMSM directly drives the moving contact of HVCB to conduct opening and closing operations [8]. As no chains, hydraulic fluid or compressed air is needed to transfer the energy, this mechanism has higher efficiency and reliability. A closed-loop control strategy is adopted in the motor drive mechanism and the operation speed of the moving contact could be precisely controlled the change of the ambient temperature and the supply voltage will also have little impact on the motor [9]. Besides, since there are already sensors for velocity, position, current and voltage in the control system of the motor, it is easy to realize continuous self check and monitoring for the operating mechanism and the HVCB.

As a whole, The Motor Drive offers a totally new and versatile way to operate HVCBs. It has the following advantages: 1) Fewer moving parts and impacts, low noise level, simple and reliable system; 2) No special power demand, no high short-term loads; 3) Operation curve could be selected due to the practical situation, with closed-loop control; 4) Contact travel is independent of ageing and change in ambient temperature; 5) Condition monitoring is inherent without the need for additional sensors.

The main focus of this paper is the control techniques for the travel curve of the breaker. The speed, position, current, and voltage sensors are installed in the control system to obtain continuous self testing and monitoring.

Fig.1 shows a demonstration of a CB operating device. In the opening operation driven by the motor-drive mechanism, the crank (8) rotates counterclockwise; pulling the insulating rod (7) down. This will quickly drive the moving arc contact (3) downwards. At the end of the opening operation, the motor applies a clockwise torque, as a buffering force, on the driving shaft (9) to decelerate the crank (8) rotation. The moving arc contact (3) speed will smoothly decrease and the mechanical impact will be limited.

During the closing operation, the crank (8) rotates clockwise in the closing operation, pushing the insulation rod (7) upwards. The moving contact (3) accelerates up toward the fixed contact. Using preset calculations and control for speed and position, the motor then applies a reverse counterclockwise torque to decelerate the moving contact, thus to reduce the mechanical impact between the breaker contacts.

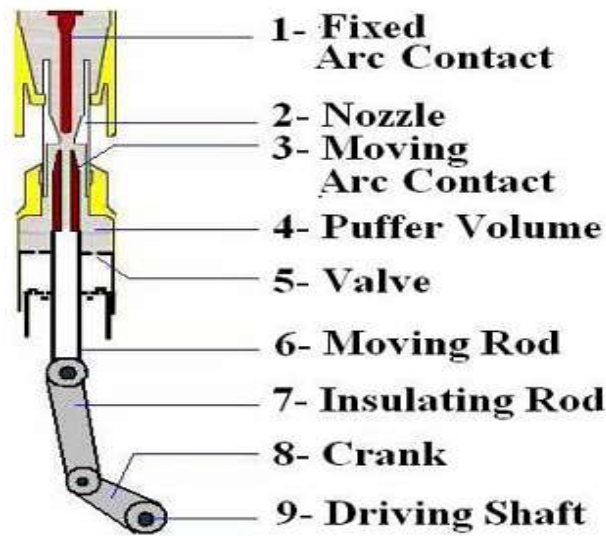

Fig.1. CB actuating device, where: 1:fixed arc contact, 2: -nozzle, 3: moving arc contact, 4: puffer volume, 5: valve, 6: moving rod, 7: insulating rod, 8: crank,9: driving shaft.

**II. SYSTEM STRUCTURE AND PRINCIPLE**

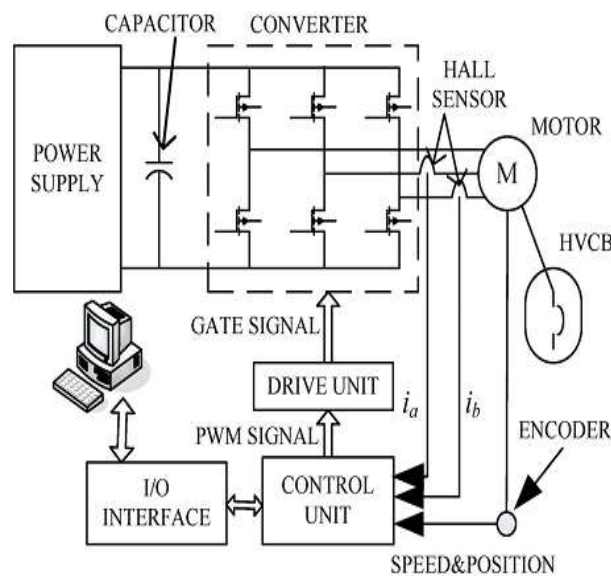

Fig.2. System diagram of the motor-drive mechanism.

The motor-drive mechanism is mainly composed of the ac/dc power supply, energy buffer capacitors, converter, and control unit and motor, shown in Fig.2.

The capacitors are the energy buffering units. Large transient current is required during the operation of a CB. The energy required is provided by the capacitors. Thus, the impact on the power supply is minimized.

The converter is composed of intelligent power modules (IPMs). The stator current is measured by hall sensors. Motor speed and rotor position are measured by the optical encoder installed in the shaft. PMSM are used in many applications that require rapid torque response and high-performance operation. The vector control method is used to control the PMSM. The basic idea of the vector control algorithm is to decompose a stator current into a magnetic field-generating component and a torque generating component. After decomposition, both components can be separately controlled like a dc machine. The speed and torque of PMSM are separately controlled.

The mathematical model of a PMSM is [9] and [10]

$$\begin{cases} u_d = p\psi_d - \omega\psi_q + Ri_d \\ u_q = p\psi_q + \omega\psi_d + Ri_q \end{cases} \quad (1)$$

Where

$$\begin{cases} \psi_d = L_d i_d + \psi_r \\ \psi_q = L_q i_q \end{cases} \quad (2)$$

$u_d$  and  $u_q$  are the d, q axis voltages,  $p$  is the differential operator  $(d)/(dt)$ ,  $i_d$  and  $i_q$  are the d, q axis stator currents,  $L_d$  and  $L_q$  are the d, q axis inductances,  $\psi_d$  and  $\psi_q$  are the d, q axis stator flux linkages, while  $R$  and  $\omega$  are the stator resistance and inverter frequency, respectively.  $\psi_r$  is the flux linkage due to the rotor magnets linking the stator. The electric torque is



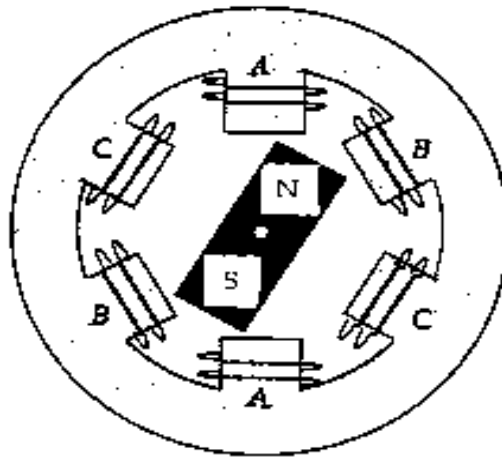

Fig.4 A three-phase synchronous motor with a one permanent magnet pair pole rotor

#### IV. MATLAB/SIMULINK RESULTS

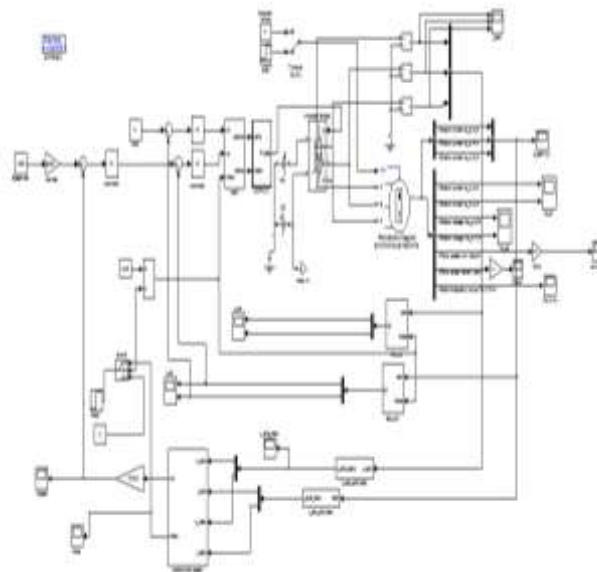

Fig.5 Simulation modeling of motor drive based operating mechanism for high voltage circuit breaker

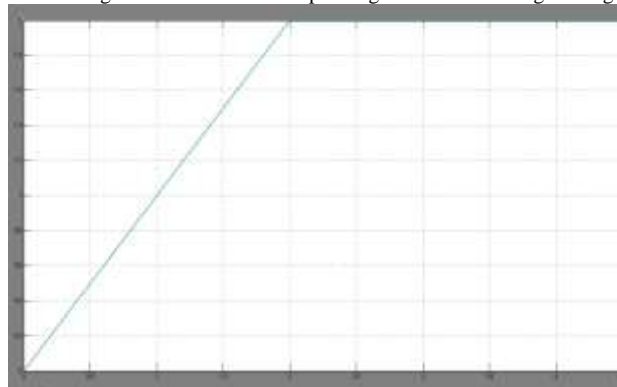

Fig.6 Motor angular speed curve

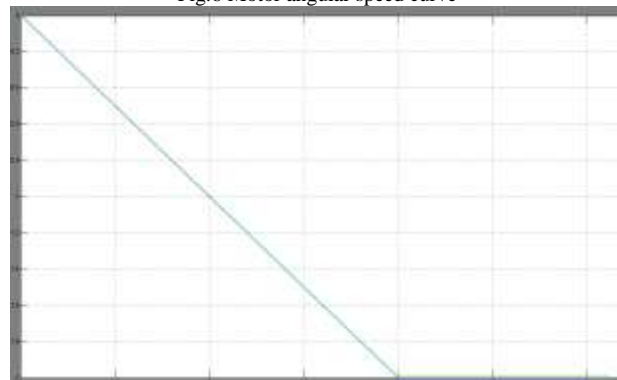

Fig.7 Motor angular displacement curve

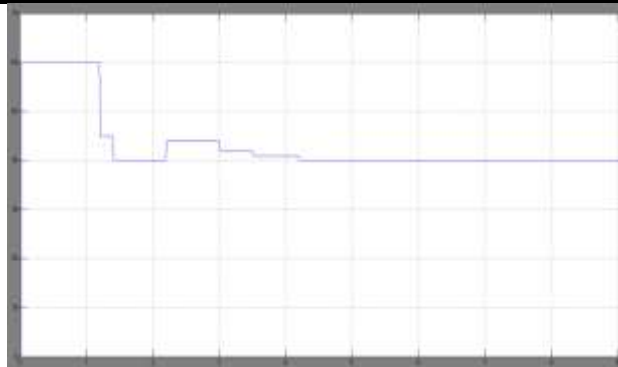

Fig.8 Stator current phase curve

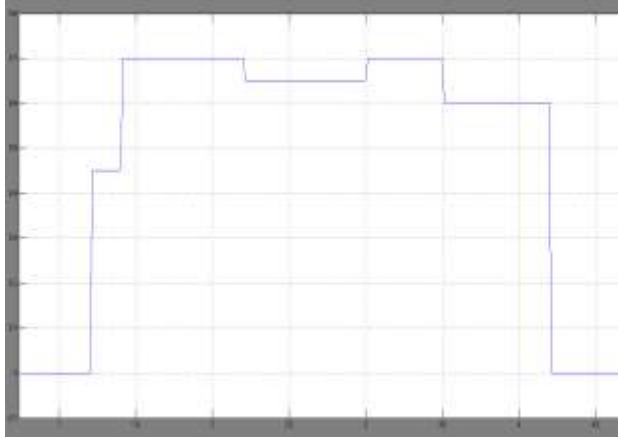

Fig.9 Motor angular displacement

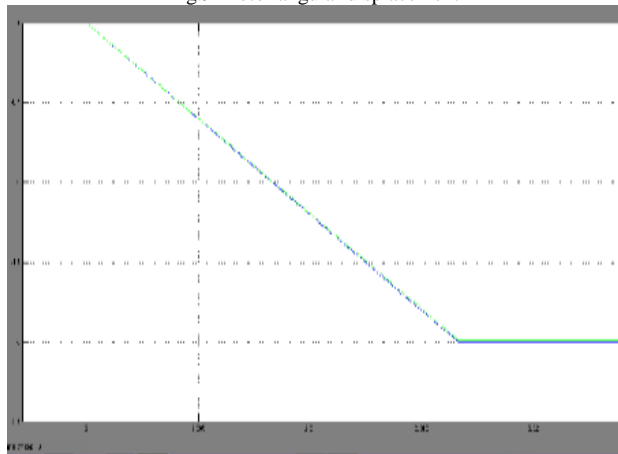

Fig.10 Motor drive mechanism opening test curve

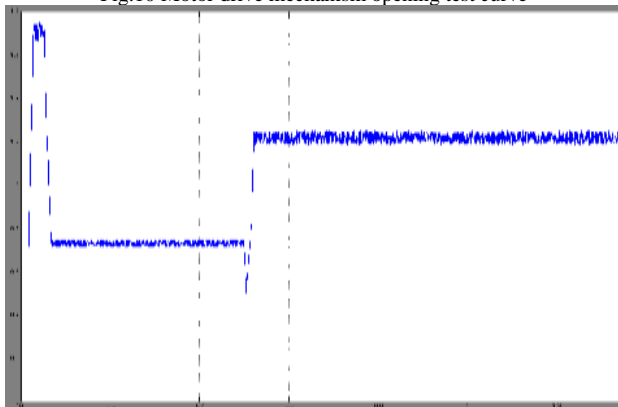

Fig.11 accelerating process in closing operation

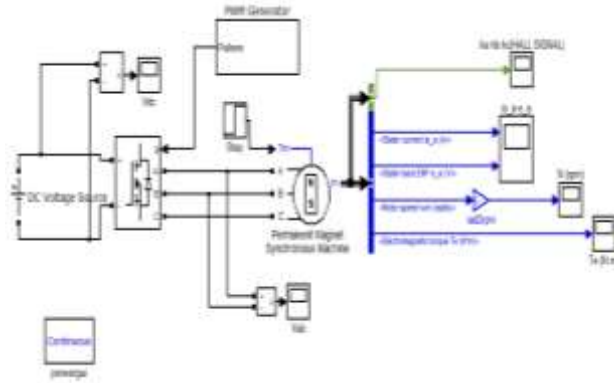

Fig.12 Simulink model of PMSM with PWM Generator

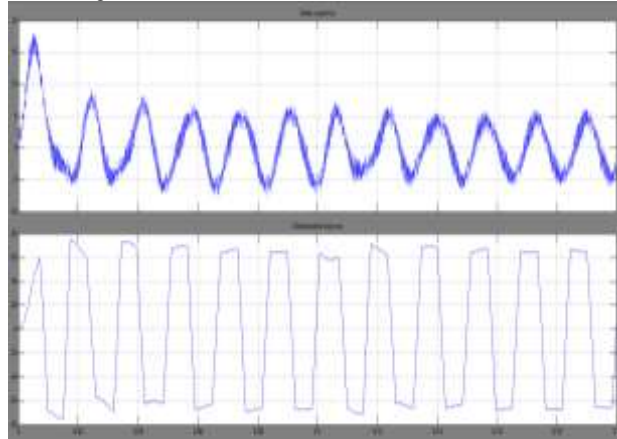

Fig.13 Stator Current and Back EMF

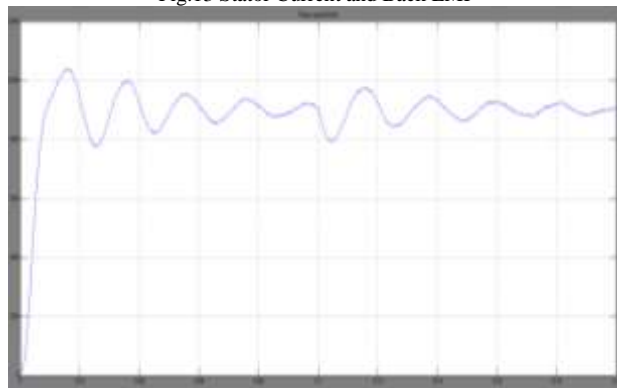

Fig.14 Speed of the motor

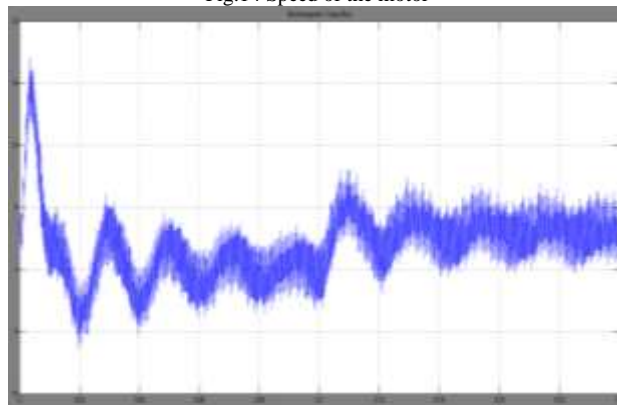

Fig.15 Torque characteristics of the motor



Fig.16 DC bus Voltage

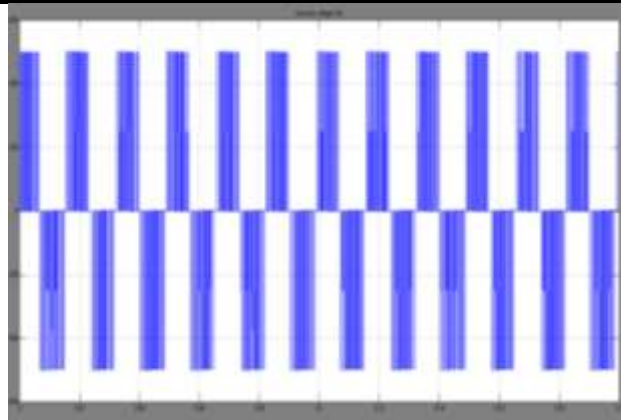

Fig.17 Inverter output Voltage

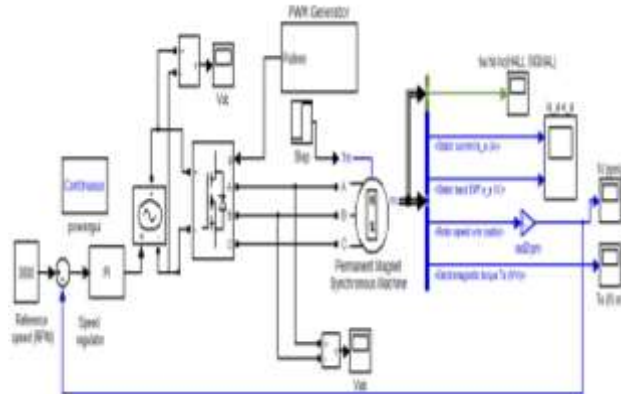

Fig.18 Simulink model of PMSM with PWM Generator with Controller

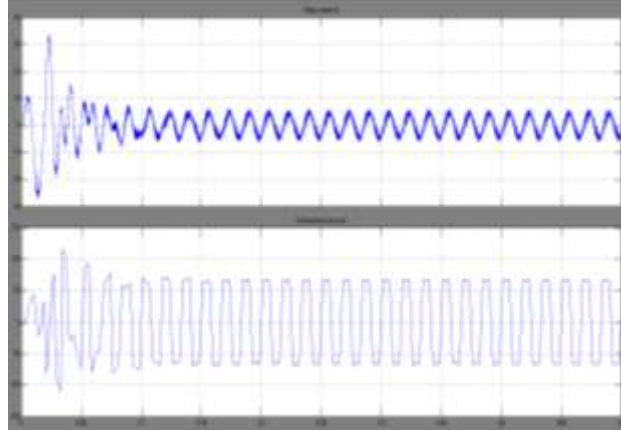

Fig.19 Stator Current and Back EMF



Fig.20 Speed of the motor

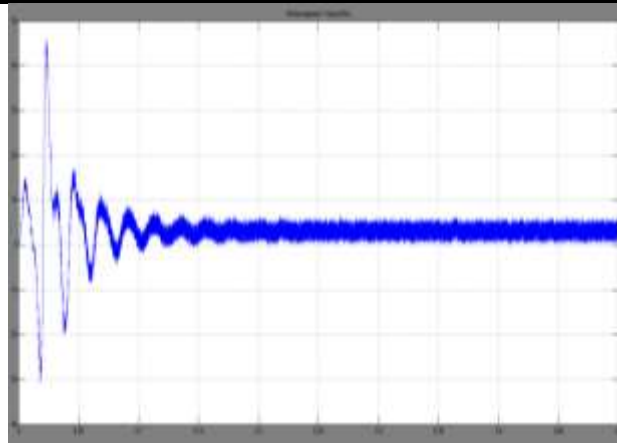

Fig.21 Torque characteristics of the motor



Fig.22 DC bus Voltage

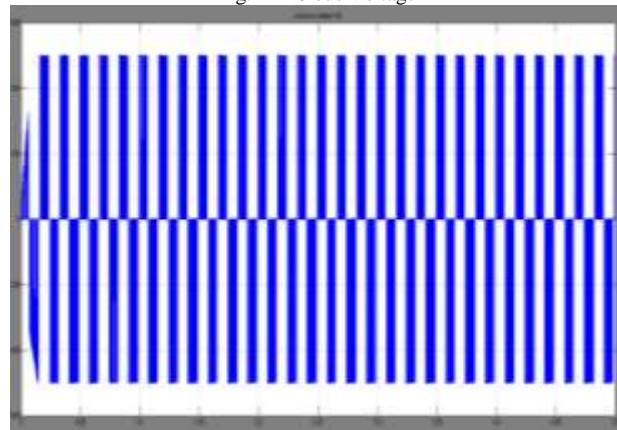

Fig.23 Inverter output Voltage

## V. CONCLUSION

Based on the operating requirements of HVCBs, this paper chooses a PMSM as the driving motor. The simulation model is established and the DSP control program is developed according to the angle-speed curve, the angle curve and the torque curve. The test results of the closed-loop control in this paper shows that with the PMSM of specified parameters, the actual opening curves of 40ms or above and the actual closing curves of 60ms or above generally go well with those presupposed curves. The results indicate that the motor drive mechanism can operate HVCBs according to the presupposed operating characteristics curves. Therefore using motors to drive the mechanisms of HVCBs is feasible and of favorable control performance. Because of impacts from the gravity and the electrical and mechanical constants of the PMSM, actual operating curves of shorter time, less than 40ms, do not go well with the presupposed ones. Therefore we should choose the PMSMs with less inertia and greater output torque for the HVCBs with heavier moving contacts and more limited operation time.



## REFERENCES

1. V. N. Maller and M. S. Naigu, *Advances in High Voltage Insulation and Arc Interruption in SF6 and Vacuum*. Oxford, U.K.: Pergamon, 1981, pp. 100–118.
2. K. Nakanishi, *Switching Phenomena in High-voltage Circuit Breakers*. New York: Marcel Dekker, 1991, pp. 102–104.
3. R. D. Garzon, *High Voltage Circuit Breakers: Design and Applications*, 2nd ed. New York: Marcel Dekker, 2002, pp. 212–216.
4. A. Bosma, F.-J. Koerber, R. Cameroni, and R. Thomas, “Motor drive with electronic control for HVAC circuit-breakers,” in *CIGRE Session 2002*, Paris, France, pp. 13–203.
5. A. Bosma and P.-O. Thureson, “A new reliable operating mechanism for HVAC circuit-breakers,” in *Proc. IEEE/Power Energy Soc. Transm. Distrib. Conf. Expo.*, Oct. 28–Nov. 2, 2001, pp. 573–577.
6. A. Bosma, R. Cameroni, and M. Blundell, “Introducing a new generation of operating mechanism for high voltage AC circuit-breakers,” *J. Elect. Electron. Eng.*, vol. 21, no. 3, pp. 233–240, 2002.
7. W. Jingjun, H. Yulong, and J. Qian, “An operating mechanism driven by the motor for HVCB,” presented at the 14th Int. Symp. High Voltage Eng., Beijing, China, Aug. 25–29, 2005, F-18.
8. Y. Huang, D. Li, T. Yang, J. Wang, and G. Xu, “Research on the control techniques of motor drive for SF6 high voltage circuit breaker,” presented at the *Power Syst. Technol. (POWERCON)*, Int. Conf. Power Syst. Technol., Hangzhou, China, Oct. 24–28, 2010.
9. P. Pillay and R. Krishnan, “Modeling, simulation, and analysis of permanent-magnet motor drives, Part 1: The permanent-magnet synchronous motor drive,” *IEEE Trans. Ind. Electron.*, vol. 25, no. 2, pp. 265–273, Mar./Apr. 1989