

A Novel Approach on Open Circuit Fault Detection Using Rectifier

Jillella Gopinath, N Vijay Kumar

Department of EEE, Godavari Institute of Engineering & Technology (A), Rajahmundry, Andhra Pradesh, India.

Abstract : A novel fault diagnosis method for open-circuit faults on a traction rectifier is proposed in this paper. When an open-circuit fault occurs in any leg of the rectifier, indication will be generated accurately to identify the faulty leg without utilization of any extra sensors. Furthermore, the faulty rectifier can be reconfigured to maintain its full output rate to prevent traction rectifier breakdown. The fault diagnosis process is neither related to control trigger signal nor the load fluctuation. The involved parameters are the input and output voltage of the rectifier, which are the most common parameters in rectifier control. Here five additional switch sets are adopted for the fault diagnosis process to reconfigure the topological structure between traction rectifier and traction transformer. In this system two set of traction rectifier is used if any rectifier set one set is affected from the open circuit fault it would be switch over to the next set then fault is diagnosed meanwhile the original structure of the rectifier is retained. Analysis, design, and implementing consideration for both normal and abnormal operating situations of the traction rectifier are present in this paper. In this method no additional sensor, many hardware requirement The experiment is processed to verify the effectiveness of the theoretical analysis.

Keywords-traction rectifier, faultdiagnosis, traction transformer.

I. INTRODUCTION

Nowadays considerable locomotive are powered by DC motor are still on active service worldwide, for example there are thousands of DC motor are continuously operating in railways, mines and factory in china. The locomotives have long service time and higher converter breakdown. The fault diagnosis and localization problems is important issue to improve safety, reduced repairing cost, and due to shutdown process and avoid accidents to guarantee a continuity of operation.

The fault statistics for on certain type of locomotive in a corporation in the second quarter of year 2015 in china , the main transformer amount ratio 4.76%. there are 42.86%of total locomotive failures. Diagnosis methods that aim at rectifiers , inverters , dc converters , and key components are discussed in categories. The fault diagnosis methods on a rectifier are discussed in this method.

There is online diagnosis is not possible because of there is two sensors and faulty switches are used a voltage based approach for open circuit fault diagnosis in closed loop control pulse width modulation converter is proposed. So any additional sensor are does not need in this method. There is many safety critical application but it do not allow any modification on original system. In this paper we include the simulation diagram simulation waveform and for rectifier control we are using PIC microcontroller we include the pin configuration and then LCD display are used to display the current states of the voltage and current.

The rectification relay are used for voltage regulation and then automatic fault rectification method we are proposed.

II. EXISTING SYSTEM

In the existing system the 230v supply is given to the step down transformer and that reduced voltage is given to the traction rectifier there is a two set of traction rectifier is used. so the first set of rectifier is supplied from transformer. There is any open circuit fault (or) unbalanced fault is occur in the first set of traction rectifier. Because open circuit the traction motor go to the OFF condition. So second set of rectifier is used it will be connected in the manually.

III. PROPOSED SYSTEM

In proposed system there is any open circuit fault and unbalanced fault in traction rectifier. Because of fault the traction motor is go to OFF condition so another set of rectifier is used it will be connected automatically. Using microcontroller the open circuit fault will be detected and it will be displayed using 2*16 LCD then diagnosis (or) rectified using microcontroller. And then the supply is automatically connected in first set of rectifier

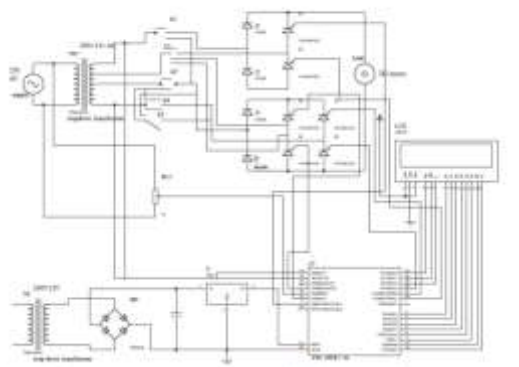

fig.1. Proposed system of traction rectifier

Controlled rectifiers are line commutated ac to dc power converters which are used to convert a fixed voltage, fixed frequency ac power supply into variable dc output voltage.

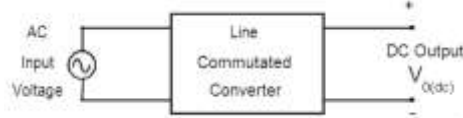

fig.2.diagram for line commutated converter

Type of output: Variable dc output voltage

The input supply fed to a controlled rectifier is ac supply at a fixed rms voltage and at a fixed frequency. We can obtain variable dc output voltage by using controlled rectifiers. By employing phase controlled thyristors in the controlled rectifier circuits we can obtain variable dc output voltage and variable dc (average) output current by varying the trigger angle (phase angle) at which the thyristors are triggered. We obtain a uni-directional and pulsating load current waveform, which has a specific average value.

The thyristors are forward biased during the positive half cycle of input supply and can be turned ON by applying suitable gate trigger pulses at the thyristor gate leads. The thyristor current and the load current begin to flow once the thyristors are triggered (turned ON) say at $\omega t = \alpha$. The load current flows when the thyristors conduct from $\omega t = \alpha$ to β . The output voltage across the load follows the input

supply voltage through the conducting thyristor. At $\omega t = \beta$, when the load current

falls to zero, the thyristors turn off due to AC line (natural) commutation. In some bridge controlled rectifier circuits the conducting thyristor turns off, when the other thyristor is (other group of thyristors are) turned ON.

The thyristor remains reverse biased during the negative half cycle of input supply. The type of commutation used in controlled rectifier circuits is referred to AC line commutation or Natural commutation or AC phase commutation.

When the input ac supply voltage reverses and becomes negative during the negative half cycle, the thyristor becomes reverse biased and hence turns off. There are several types of power converters which use ac line commutation. These are referred to as line commutated converters.

IV. PRINCIPLE OF PHASE CONTROLLED RECTIFIER OPERATION

The basic principle of operation of a phase controlled rectifier circuit is explained with reference to a single phase half wave phase controlled rectifier circuit with a resistive load shown in the figure.

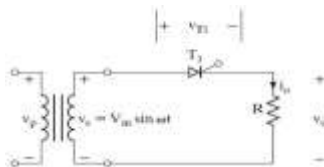

Fig.3.Single Phase Half-Wave Thyristor Converter with a Resistive Load

A single phase half wave thyristor converter which is used for ac-dc power conversion is shown in the above figure. The input ac supply is obtained from a main supply transformer to provide the desired ac supply voltage to the thyristor converter depending on the output dc voltage required. v_p represents the primary input ac supply voltage. v_s represents the secondary ac supply voltage which is the output of the transformer secondary. During the positive half cycle of input supply when the upper end of the transformer secondary is at a positive potential with respect to the lower end, the thyristor anode is positive with respect to its cathode and the thyristor is in a forward biased state. The thyristor is triggered at a delay angle of $\omega t = \alpha$, by applying a suitable gate trigger pulse to the gate lead of thyristor. When the thyristor is triggered at a delay angle of $\omega t = \alpha$, the thyristor conducts and assuming an ideal thyristor, the thyristor behaves as a closed switch and the input supply voltage appears across the load when the thyristor conducts from $\omega t = \alpha$ to π radians. Output voltage $v_o = v_s$, when the thyristor conducts from $\omega t = \alpha$ to π . For a purely resistive load, the load current i_o (output current) that flows when the thyristor T_1 is on.

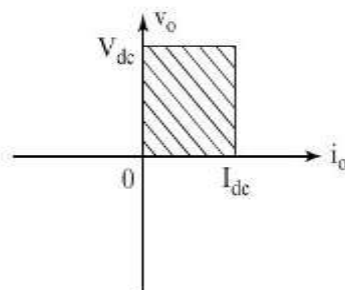

fig.4.wave form of thyristor

During the negative half cycle of input supply when the supply voltage reverses and becomes negative during $\omega t = \pi$ to 2π radians, the anode of thyristor is at a negative potential with respect to its cathode and as a result the thyristor is reverse biased and hence it remains cut-off (in the reverse blocking mode). The thyristor cannot conduct during its reverse biased state between $\omega t = \pi$ to 2π . An ideal thyristor under reverse biased condition behaves as an open switch and hence the load current and load voltage are zero during $\omega t = \pi$ to 2π . The maximum or peak reverse voltage that appears across the thyristor anode and cathode terminals is V_m .

The trigger angle α (delay angle or the phase angle α) is measured from the beginning of each positive half cycle to the time instant when the gate trigger pulse is applied. The thyristor conduction angle is from α to π , hence the conduction angle $\delta = (\pi - \alpha)$. The maximum conduction angle is π radians (180°) when the trigger angle $\alpha = 0$.

The waveforms shows the input ac supply voltage across the secondary winding of the transformer which is represented as v_s , the output voltage across the load, the output (load) current, and the thyristor voltage waveform that appears across the anode and cathode terminals.

V. HARDWARE DIAGRAM

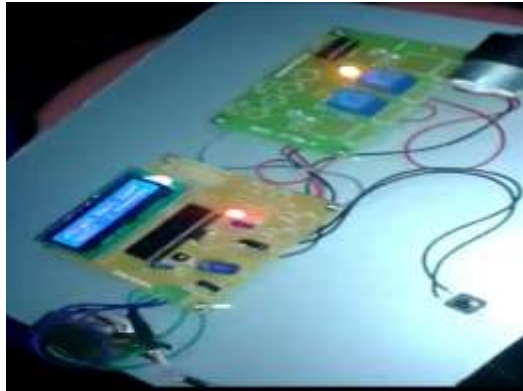

fig.5 hardware circuit diagram

There are many types of power supply. Most are designed to convert high voltage AC mains electricity to a suitable low voltage supply for electronic circuits and other devices. A power supply can be broken down into a series of blocks, each of which performs a particular function

For example a 5V regulated supply:

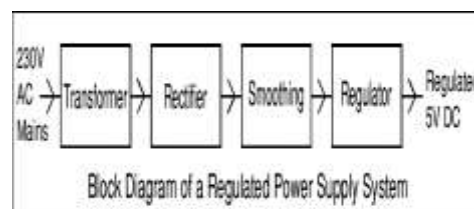

fig.6.block diagram of regulated power supply

Each of the blocks is described in more detail below:

- Transformer - steps down high voltage AC mains to low voltage AC.
- Rectifier - converts AC to DC, but the DC output is varying.
- Smoothing - smooth's the DC from varying greatly to a small ripple.
- Regulator - eliminates ripple by setting DC output to a fixed voltage

VI. TRANSFORMER

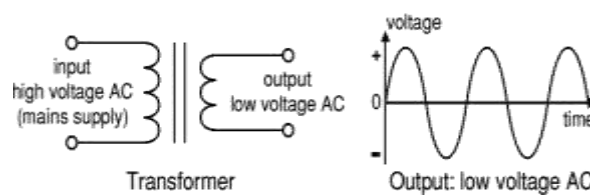
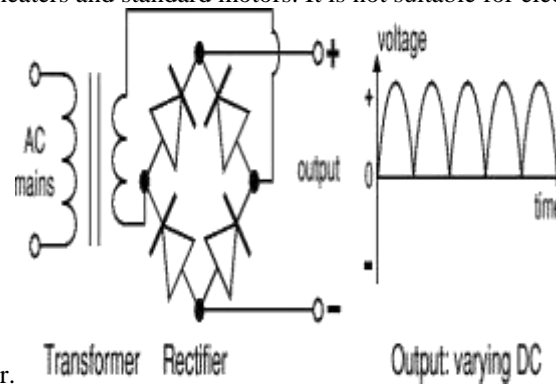

Fig.7.Transformer

The **low voltage AC** output is suitable for lamps, heaters and special AC motors. It is **not** suitable for electronic circuits unless they include a rectifier and a smoothing capacitor

A. Transformer + Rectifier:

The varying DC output is suitable for lamps, heaters and standard motors. It is not suitable for electronic circuits unless they



include a smoothing capacitor.

Fig.8 Transformer Rectifier

B. Transformer + Rectifier + Smoothing:

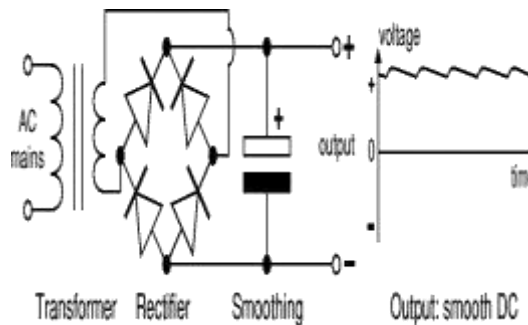

Fig.9. Transformer rectifier smoothing

The smooth DC output has a small ripple. It is suitable for most electronic circuits.

C. Transformer + Rectifier + Smoothing + Regulator:

The **regulated DC** output is very smooth with no ripple. It is suitable for all electronic circuits

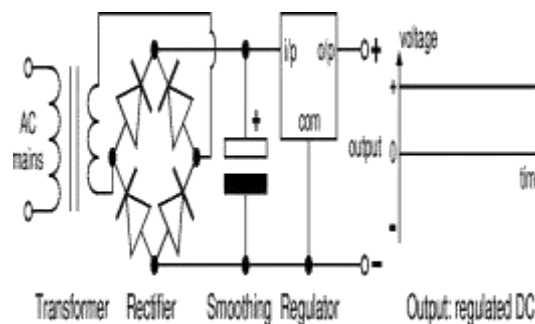

Fig.10. Transformer Rectifier Smoothing Regulator

Transformers convert AC electricity from one voltage to another with little loss of power. Transformers work only with AC and this is one of the reasons why mains electricity is AC. Step-up transformers increase voltage, step-down transformers reduce voltage. Most power supplies use a step-down transformer to reduce the dangerously high mains voltage (230V in UK) to a safer low voltage. The input coil is called the **primary** and the output coil is called the **secondary**. There is no electrical connection between the two coils; instead they are linked by an alternating magnetic field created in the soft-iron core of the transformer. The two lines in the middle of the circuit symbol represent the core.

VII. SIMULATION RESULT

A.FIRST TRACTION RECTIFIER OUTPUT

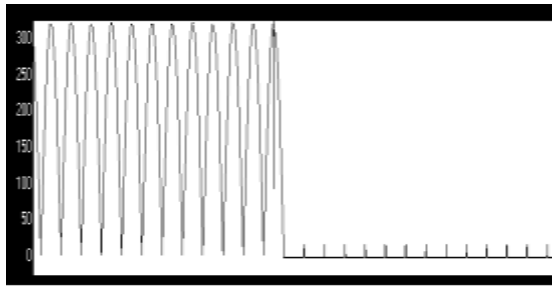

fig.11.wave form of first traction rectifier output

VIII. SIMULATION DIAGRAM

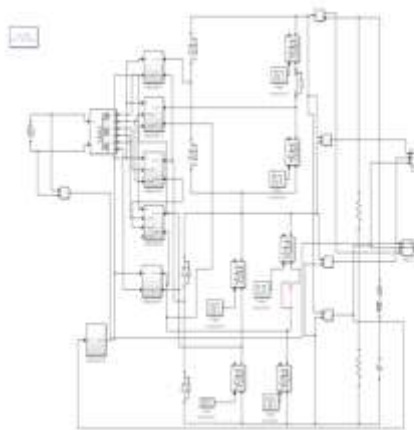

fig.12.simulation diagram

B.SECOND TRACT ION RECTIFIER OUTPUT

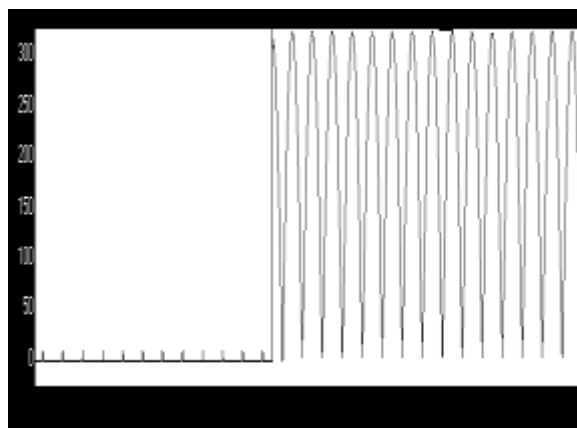

fig.13.wave form for second traction rectifier

C.LOAD OUTPUT VOLTAGE

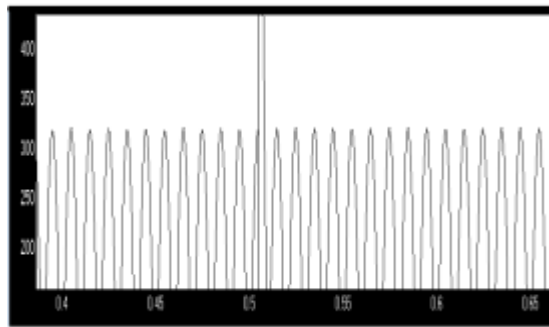

fig.14.wavwform of load output voltage

D.INPUT VOLTAGE

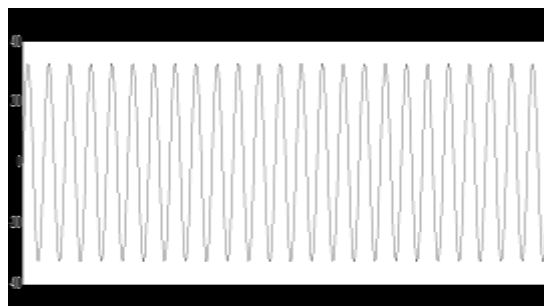
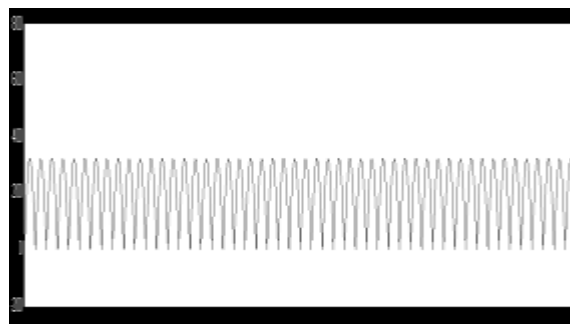

fig.15.wave from for input voltage

E.OUTPUT VOLTAGE



F.OUTPUT CURRENT

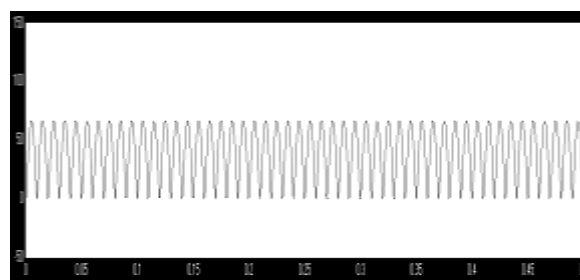

fig.16.waveform for output voltage

IX. CONCLUSION

The new method can achieve diagnosis of any semiconductor device open-circuit fault in a short time period without either extra sensors or system structure changing. Moreover, the rectifier can maintain its full load capacity after being reconfigured according to the proposed fault tolerance control strategy. The validity and efficiency of the proposed fault diagnosis method and the fault tolerance control strategy are verified by experiment results. All the experimental results suggest that the new method is suitable for traction rectifier fault diagnosis and fault tolerance control. Due to the limitation of the experimental condition, the prototype has not been tested in the real traction rectifier. The next step of this study is multiple semiconductor open-circuit fault diagnosis.

REFERENCES

- [1] H. Chen and S. Lu, "Fault diagnosis digital method for power transistors in power converters of switched reluctance motors," *IEEE Trans. Ind. Electron.*, vol. 60, no. 2, pp. 749–764, Feb. 2013.
- [2] J. F. Marques, J. O. Estima, N. S. Gameiro, and A. J. Marques Cardoso, "A new diagnostic technique for real-time diagnosis of power converter faults in switched reluctance motor drives," *IEEE Trans. Ind. Appl.*, vol. 50, no. 3, pp. 1854–1860, May/Jun. 2014.
- [3] T. Kamel, Y. Biletskiy, and L. Chang, "Real-time diagnosis for opencircuited and unbalance faults in electronic converters connected to residential wind systems," *IEEE Trans. Ind. Electron.*, vol. 63, no. 3, pp. 1781–1792, Feb. 2016.
- [4] N. M. A. Freire, J. O. Estima, and A. J. M. Cardoso, "A voltage-based approach without extra hardware for open-circuit fault diagnosis in closedloop PWM AC regenerative drives," *IEEE Trans. Ind. Appl.*, vol. 61, no. 9, pp. 4960–4971, Sep. 2014.
- [5] I. Jlassi, J. O. Estima, E. Khil, S. Khojet, N. M. Bellaaj, and A. J. Marques Cardoso, "Multiple open-circuit faults diagnosis in back-to-back converters of PMSG drives for wind turbine systems," *IEEE Trans. Power Electron.*, vol. 30, no. 5, pp. 2689–2703, May 2015.
- [6] C. Brunson, L. Empringham, L. De Lillo, P. Wheeler, and J. Clare, "Opencircuit fault detection and diagnosis in matrix converters," *IEEE Trans. Power Electron.*, vol. 30, no. 5, pp. 2840–2848, May 2015.
- [7] W. Sleszynski, J. Nieznanski, and A. Cichowski, "Open-transistor fault diagnostics in voltage-source inverters by analyzing the load currents," *IEEE Trans. Ind. Elect.*, vol. 56, no. 11, pp. 4681–4688, Nov. 2009.
- [8] S.-M. Jung, J.-S. Park, H.-W. Kim, K.-Y. Cho, and M.-J. Youn, "An MRAS-based diagnosis of open-circuit fault in PWM voltage-source inverters for PM synchronous motor drive systems," *IEEE Trans. Power Electron.*, vol. 28, no. 5, pp. 2514–2526, May 2013