

A COMPARITIVE ANALYSIS ON LI- FI FRAMEWORK

Prof. K.Jayamalini¹, Alfia Imtiaz Munshi²

Professor, Department of Computer Engineering, Mumbai University

Research Scholar, Department of Computer Engineering, Mumbai University

Abstract: The advancement is outstandingly new and was proposed by the German physicist Harald Haas in 2011. It is based on Visible Light Communication (VLC). Li-Fi is a far off optical frameworks organization development that uses light producing diodes (LEDs) for transmission of data. The designing benefits light as a medium to pass on quick correspondence in a manner homogeneous to a Wi-Fi. This advancement has benefits like security, extended open reach, low inactivity efficiency and significantly higher speed when appeared differently in relation to Wi-Fi. This paper tries to clarify the thought and approaches of Li-Fi advancement. Likewise, for outside applications, photovoltaic modules give off an impression of being interesting alternatives to photodiode-based old style identifiers. They are definitely known to offer a more raised degree of adaptability to submersion impacts. The current Wi-Fi association utilizes Radio Frequency waves; anyway the utilization of the available RF range is limited. Therefore another development, Li-Fi has come into picture. Be that as it may, this paper revolves around Li-Fi, its applications, features and relationship with existing advances like Wi-Fi, etc. Wi-Fi is of huge use for general far off incorporation inside building, while Li-Fi is ideal for high thickness far off data consideration in bound region and especially significant for applications in domains where radio impedance issues are of concern, so the two headways can be seen as free. Li-Fi gives better information transmission, capability, organization and security than Wi-Fi. The thought can be completed at outrageous straightforwardness and with higher profitability. As of now, the ordinary activities use some portion of LEDs based lights for edification, which can moreover be used for correspondence in light, remembering the advantages like quick exchanging, high force proficiency and protected to human vision.

Index terms: Light Fidelity (LiFi); Visible Light Communication (VLC), wireless communication technologies.

I. INTRODUCTION

These days of stuck (data correspondence), Li-Fi is another and beneficial strategy for far off correspondence. Li-Fi uses LED lights to send data. The Transmission of data is done distantly. The current far off associations that interface us to the Internet ends up being extraordinarily lazy when various devices are related. Similarly with the development in the quantity of devices, which uses the Internet, the availability of fixed bandwidth makes it extensively harder to value high data move rates and to relate a protected association. Radio waves are just a little piece of the electromagnetic reach which is open for data move. Li-Fi has much more broad reach for transmission of data stood out from standard systems for distant trades that are done on radio waves. The fundamental idea behind this advancement is that the data can be travelled through LED light by varying light powers snappier than the regular eyes can't distinguish.

The suggestion of Li-Fi was introduced strangely by a German physicist Harald Haas in the TED (Technology, Entertainment, and Design) Global visit on Visible Light Communication (VLC) in July 2011, by introducing it as "information through enlightenment". He used a table light with a determined bulb to convey a video of a blooming sprout that was by then projected onto a screen. In essential terms, Li-Fi can be considered as a light-based Wi-Fi; rather than radio waves it uses light to impart data. By adding new and unutilized bandwidth of obvious light to the as of now accessible radio waves for data move, Li-Fi can expect a huge part in facilitating the heavy weights which the current far off structure is standing up to. Thusly it may offer additional repeat band of the solicitation for 400 THz diverged from that open in RF correspondence which is around 300

GHz. By Communication through clear light, Li-Fi advancement has the probability to change how we access the Internet, move chronicles, and get messages and fundamentally more. Security would not be an issue as data can't be gotten to without light. Consequently, it will in general be used in high security military districts where RF correspondence is slanted to listening in. The following is the reason for utilizing noticeable light correspondence:

- Infrared, because of eye wellbeing guideline, must be with low force.
- Radio waves infiltrate through the dividers so they emerges security issues.
- X-beams have comparable medical problems.
- The Gamma beams can't be utilized as they could be risky.

II. MATERIALS AND METHODS

Earlier, the radio waves were used; anyway they were expensive and less secure. Infrared, should be used with low force concerning the reason for eye prosperity. Gamma radiates can't be used as they can wind up being hazardous. Splendid light is helpful for place which is freed from individuals regardless can be dangerous to individuals. Since noticeable light has no risky effects, it might be ensured to use and is in addition having a greater bandwidth. VLC is a data correspondence medium, which uses clear light in the extent of 400THz to 800THz as optical carrier for data transmission and enlightenment. Figure 1 shows the scope of electromagnetic range of light.

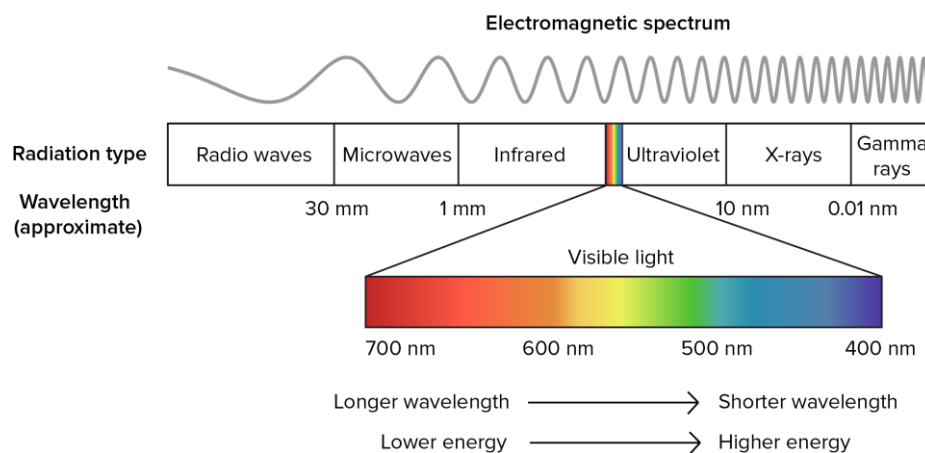

Figure1: Electromagnetic spectrum of light

Figure 1 shows part of the electromagnetic range with the optical reach called attention to. Huge specialized and operational benefits are offered by optical remote correspondence (OWC) frameworks, for example, low force necessities, a lot bigger transfer speed limit, solid security, power to electromagnetic impedance and lenient range. OWC can be applied on a huge area of correspondence applications, starting with millimetres range interconnected inside coordinated circuits through open air kilometres joins.

LiFi uses noticeable light as the multiplication medium in the downlink for the explanations behind light and correspondence. It can use infrared in the uplink so the illumination basic of a room stays unaffected, and besides to keep an essential separation from impedance with the conspicuous light in the downlink [1]. LiFi offers different critical benefits that have made it extraordinary for later and future investigation. These incorporate the exceptionally huge, unregulated data transmission accessible in the obvious light range (in excess of multiple times more significant than the whole RF range), high energy profitability [2], the genuinely clear sending which uses off-the-rack light creating diodes (LED) and photodiode (PD) devices at the transmitter and authority closes independently, and overhauled security as light doesn't enter through cloudy articles [3]. One of the fundamental lacks of the stream research composing on LiFi is the shortfall of fitting estimations of

device course and insurgency displaying for framework plan and handover the board purposes. Cells are the most basic and fundamental piece of distant association delivering about 86% of the adaptable data traffic [4]. LiFi as a component of future 5G can deal with this huge data traffic due to future LiFi-engaged phones. All things considered, customers will overall work with their PDAs in a pleasant manner which isn't actually vertically upward. PDAs are outfitted with a spinner that can check the contraption heading. This course information can be taken care of back to the path (AP) through limited info procedures.

As WI-FI territory of interest and circulated processing are rapidly extending solid sign will undoubtedly endure. They are feeble against developers as it invades through dividers with no issue. LI-FI is said to crush this. This new development is similar to infrared regulators which send data through LED light that varies in power faster than the characteristic eye can see. In not so removed future we can see data for PCs, sharp phones and tablets sent through the light in a room. Li-Fi (Light Fidelity) is a fast and unassuming optical variation of Wi-Fi, the advancement of which relies upon Visible Light Communication (VLC). The basic portion of this correspondence system is a high splendour white LED, Which goes probably as a correspondence source and a silicon photodiode which shows incredible response to clear recurrence locale filling in as the getting part. Driven can be turned here and there to make progressed arrangement of 1s and 0s. Data can be encoded in the light to make another data stream by changing the sparkling speed of the LED. To be all the more clear, by changing the LED light with the data signal, the LED light can be used as a correspondence source. As the sparkling rate is so speedy, the LED yield appears consistent to the regular eye. A data speed of more noticeable than 100 Mbps is possible by using quick LEDs with fitting multiplexing techniques. VLC data rate can be extended by equivalent data transmission using LED shows where each LED conveys another data stream. There are inspirations to support LED as the light source in VLC, while a lot of other illumination contraptions like glaring light, sparkling bulb, etc are open. LI-FI advancement uses semiconductor contraption LED light that rapidly makes matched signs which can be controlled to send data by little changes in abundance. Using these creative development 10000 to 20000 pieces for each second of data can be sent simultaneously in equivalent using a phenomenal sign dealing with advancement and uncommon adjustment.

A. System Design of a Li-Fi

Li-Fi which can be the eventual fate of information correspondence as it shows up of being a speedy and unobtrusive optical type of Wi-Fi. Being a Visible Light Communication (VLC), Li-Fi jobs clear light of electromagnetic reach between 400 THz cap's more, 800 THz as optical carrier for data transmission and illumination. It uses snappy beats of light to convey information in far off medium. The basic fragments of a basic Li-Fi structure may contain the going with:

- A high splendour white LED which goes about as transmission source.
- A silicon photodiode with incredible response to noticeable light as the getting segment.

Turning the LEDs on and can make them produce progressed strings with different blend of 1s and 0s. To deliver another data stream, data can be encoded in the light by changing the glinting speed of the LED. Thusly, the LEDs fill in as a transmitter by offsetting the light with the data signal. The LED yield appears consistent to the human since they are made to streak at an astounding speed and it's incomprehensible for natural eye to recognize this repeat. Correspondence rate more than 100 Mbps can be cultivated by using high speed LEDs with the help of various multiplexing techniques. Likewise, this VLC data rate can be moreover extended to as high as 10 Gbps through equivalent data transmission using an assortment of LED lights with each LED sending an other data stream. The Li-Fi transmitter framework comprises of four essential subassemblies:

- Bulb
- RF Power Amplifier Circuit (PA)
- Printed Circuit Board (PCB)

- Enclosure

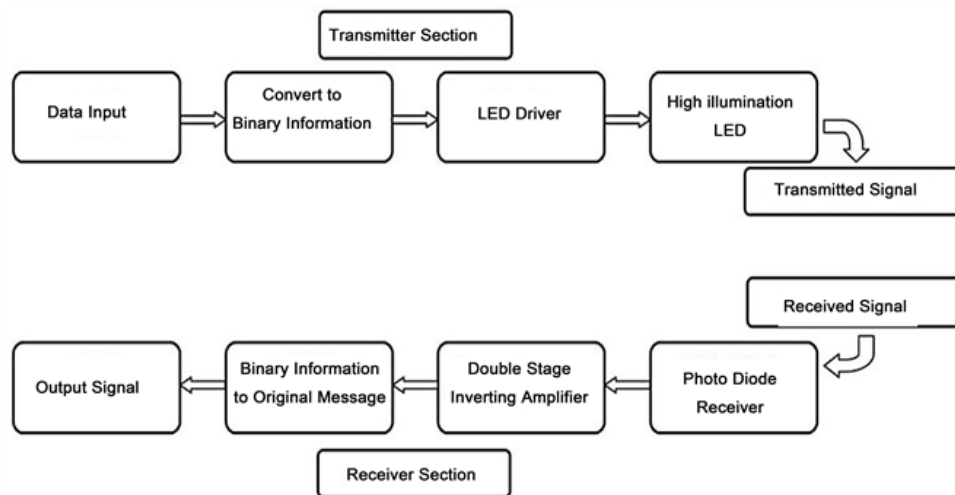

Figure1: Block Diagram of a Li-Fi

The Printed circuit board (PCB) controls the electrical wellsprings of data and yields of the light and houses the microcontroller used to direct unmistakable light limits. A Radio Frequency (RF) signal is made by the Power Enhancer and is facilitated into the electric field of the bulb. As a result of the incredible intermingling of energy in the electric field, the substance of the bulb will get deteriorated into a plasma state at the bulb's center. Additionally, this controlled plasma will make an uncommon wellspring of light.

B. Comparative Analysis between Li-Fi and Wi-Fi

Both Wi-Fi and Li-Fi can give far off Internet induction to customers, and both the advances impart data over electromagnetic reach. Li-Fi is an undeniable light correspondence development supportive to get high speed far off correspondence. What is important is: Wi-Fi development uses radio waves for transmission; however Li-Fi utilizes light waves. Wi-Fi works commendably for general far off incorporation inside building/grounds/compound, and Li-Fi is ideal for high thickness far off data consideration inside a limited area or room and is freed from impediment issues not under any condition like the Wi-Fi. Table I shows an examination of Li-Fi with Wi-Fi.

Parameter	Li-Fi	Wi-Fi
Spectrum Used	Visible Light	RF
Standard	IEEE 802.15.7	IEEE 802.11
Range	Based on Light Intensity (< 10m)	Based on Radio propagation & interference (< 300 m)
Data Transfer Rate	Very high (~1 Gbps)	Low (100 Mbps-1 Gbps)
Power consumption	Low	High
Cost	Low	High
Bandwidth	Unlimited	limited

Table2: Comparison of Wi-Fi and Li-Fi

C. Inferences and Challenges Faced

LiFi, as a potential substitute of Wi-Fi radio waves approaching clog and remote no man's lands, has characteristics and inadequacies that put it in contention with other industry; unequivocal advancements like RFID and iBeacons. Regardless of anything else, we think about this new advancement's speed as the main strength. By then, security, ease, nonappearance of

electromagnetic earthy colored fog what's more, as such okay for human use, more energy pleasant are a couple of various characteristics that worth being considered.

- High Speed

Information speeds of 1 Gbps have been represented using single phosphor-shrouded white LEDs [5]; later 3.4 Gbps has been displayed with an off-the-rack red-green-blue (RGB) LED [6]. Researchers of the University of Edinburgh uncovered 3.5 Gbps from a singular concealing vague LED [7]. Haas' gathering masterminded business speeds of up to 100 Gbps, this speed being plausible for LiFi when the whole observable reach is utilized [8]. The University of Oxford LiFi researchers hit 224 Gbps in lab conditions (at this speed, one moment is adequate to download five first rate films). Continuous examinations have shown data speeds of 14 Gbps for LiFi using three off-the-shelf RGB laser diodes. 42.8 Gbit/s has been cultivated for indoor OWC with 2-dimensional optical bar coordinating, on 2015. Data speeds of 1 Gbps has been represented using single phosphor-shrouded white LEDs [5]; later 3.4 Gbps has been displayed with an off-the-rack red-green-blue (RGB) LED [6]. Researchers of the University of Edinburgh uncovered 3.5 Gbps from a singular concealing vague LED [7]. Haas' gathering masterminded business Data speeds of 1 Gbps has been represented using single phosphor-shrouded white LEDs [5]; later 3.4 Gbps has been shown with an off-the-rack red-green-blue (RGB) LED [6]. Researchers of the University of Edinburgh uncovered 3.5 Gbps from a singular concealing equivocal LED [7]. Haas' gathering orchestrated business speeds of up to 100 Gbps, this speed being attainable for LiFi when the whole recognizable reach is utilized [8]. The University of Oxford LiFi researchers hit 224 Gbps in lab conditions (at this speed, one moment is adequate to download five first class films). Progressing examinations have shown data speeds of 14 Gbps for LiFi using three off-the-shelf RGB laser diodes. 42.8 Gbit/s has been refined for indoor OWC with 2-dimensional optical bar coordinating, on 2015. iceable territory is utilized [8]. The University of Oxford LiFi researchers hit 224 Gbps in lab conditions (at this speed, one moment is adequate to download five first class films). Continuous examinations have shown data speeds of 14 Gbps for LiFi using three off-the-shelf RGB laser diodes. 42.8 Gbit/s has been cultivated for indoor OWC with 2-dimensional optical bar coordinating, on 2015.

- Security

LiFi optical signs can't enter dividers, this being an advantage comparing to security issues. The same feature can be manhandled to discard deterrents between bordering cells. During the latest ten years, there have been constant reports of improved feature point interface data rates using off-the-rack white LEDs under test lab conditions [9].

- Low Energy Consumption

Considering that, for the most part, inside lights are ON more often than not, the energy utilized for correspondence would essentially be zero as a result of data on illumination. Energy efficient intensity modulation (IM) methods permit information correspondence regardless of whether the lights are outwardly off.

III. PROPOSED METHODOLOGY

Light Fidelity (Li-Fi) advancement is a distant correspondence system reliant on the use of observable light between the violet (800 THz) and red (400 THz). Unlike Wi-Fi which uses the radio piece of the electromagnetic reach, Li-Fi uses the optical reach for instance Noticeable light piece of the electromagnetic reach. The rule of Li-Fi relies upon sending data by adequacy guideline of the light source in an overall described and standardized manner. LEDs can be turned to a great extent faster than the regular eyes can perceive since the functioning speed of LEDs is under 1 microsecond. This impalpable trading development enables data transmission using equal codes. If the LED is on, a high level sign '1' is imparted and if the LED is off, an electronic sign '0' is conveyed. Moreover these LEDs can be turned on besides, off quickly which gives us a respectable possibility for sending data through LED lights, because there are no meddling light frequencies like that of the radio frequencies in Wi-Fi. Li-Fi is accepted to be 80% more successful, which infers it can show up at speeds of up to 1Gbps what's more, even past. Li-Fi shifts from fiber optic because the Li-Fi show layers are fitting for far off correspondence over brief distances (up to 10 meters). This places Li-Fi in a unique technique for exceptionally brisk and compelling far off correspondence over brief distances. The sensors on the less than desirable end get the information as light flag and unravel the data, which is then shown

on the gadget associated with the collector. The beneficiary (photograph locator) enlists a parallel '1' when the transmitter (LED) is ON and a paired '0' when the transmitter (LED) is OFF. Hence blazing the LED various occasions or utilizing a variety of LEDs (maybe of a couple of various tones) will ultimately give information rates in the scope of many Mbps.

Consequently everything necessary, is a few or a variety of LEDs and a regulator that controls/encodes information into those LEDs. Every one of the one needs to do is to shift the rate at which the LEDs glint contingent on the information contribution to LEDs. Further information rate improvements can be made in this strategy, by utilizing exhibit of the LEDs for equal information transmission, or utilizing combinations of red , green and blue LEDs to modify the light's recurrence, with every recurrence encoding an alternate information channel. Applications of Li-Fi

- Education frameworks: Li-Fi is the latest development that can give fastest speed to Internet access. Along these lines, it can grow/supersede Wi-Fi at informational foundations and at associations so people there can use Li-Fi with the high speed.
- Medical Implementations: Activity theaters (ATs) don't allow Wi-Fi in view of radiation concerns. Use of Wi-Fi at crisis facilities intrudes/blocks the signs for checking equipment's. Consequently, it may have dangerous effect on the patient's prosperity, in view of improper working of clinical mechanical get together. To overcome this and to make OT instructed Li-Fi can be used to will web and besides to control clinical equipment's. This will be valuable for driving mechanical operations and other modernized strategies.
- Cheaper Aircrafts: The voyagers going in planes acquire permission to low speed Internet that too at an extreme expense. In like manner Wi-Fi isn't used considering the way that it may interfere with the navigational structures of the pilots. In planes Li-Fi can be used for data transmission. Li-Fi can without a very remarkable stretch give quick Internet through each light source like getting bulb, etc present inside the plane.
- Underwater usage: Submerged ROVs (Remotely Operated Vehicles) work from gigantic connections that supply their force and license them to get signals from their pilots above. Nonetheless, the chain used in ROVs isn't adequately long to allow them to examine greater locales. If their wires were replaced with light — say from a brought down, amazing light — by then they would be significantly more freed to examine. They could similarly think cautiously to talk with each other, taking care of data independently and sending their revelations irregularly back to the surface. Li-Fi can even work lowered where Wi-Fi bombs absolutely, thusly opening up limitless opportunities for military lowered undertakings.
- Disaster the executives: Li-Fi can be used as extraordinary strategies for correspondence in field of calamity like seismic quake or typhoons. The typical people might not have an idea about the shows during such disasters. Metro stations and sections, customary no man's properties for most emergency correspondences, address no hindrance for Li-Fi.

Impediments of Li-Fi

- Internet can't work without a light source. This could confine the territories in circumstances where Li-Fi could be used.
- Opaque obstructions on pathways can impact data transmission. Trademark light, sunshine, and customary electric light can impact the data transmission speed.
- Light waves don't go through dividers in this way Li-Fi has much more restricted reach than Wi-Fi.
- High beginning foundation cost, at whatever point used to set up an undeniable data association.
- Yet to be made for mass scale gathering.

Features of Li-Fi

- Bandwidth: The noticeable light range is plentiful, much more than RF and furthermore is allowed to utilize.
- Data Density: Li-Fi can accomplish multiple times the information thickness of Wi-Fi, as noticeable light can be well contained in the light enlightenment yet in instance of RF it experiences impedence.
- High Speed: An extremely rapid of information access can be accomplished from Li-Fi as it is liberated from obstruction and furthermore is having an enormous data transfer capacity.

IV. RESULTS AND DISCUSSION

As observed through the research analysis, the electromagnetic range turns out to be constantly packed, the LiFi innovation vows to give a quicker, more secure, greener, better and better future for remote correspondence framework. Exactly when this system will be totally developed, each light source can be used as a LiFi way, which implies where will be a LED light we can expect to have data correspondence office, also. A few years, we expect to see LiFi besides with other distant complementary advances to make another all inclusive enlisting stage. Under this looming joining, every contraption adequately enormous to mount a LED and a light sensor can be related and constrained by LiFi.

V. FUTURE SCOPE

Vehicle to Vehicle is a moving space in auto industry and its execution utilizing Li-Fi can be expanded. The field has wide extension progressively as this implementation helps in making vehicle development self-governing and hence transportation framework brilliant. This future application includes trade of information identified with wellbeing and tasks among vehicles and foundation. These correspondences can be executed utilizing Li-Fi Technology.

At Present, LBS (Location Based Service) or Broadcast are financially open. The resulting stage could be a Li-Fi WLAN for B2B market with high included worth express business cases and could create towards mass market. Eventually, the Li-Fi could transform into an elective response for radio for far off high data rate room organization and new changed help, as expanded or increased reality.

VI. CONCLUSION

Notwithstanding the way that there's at this point far to make this development a business accomplishment, it ensures a phenomenal potential in the field of distant web. A basic number of trained professionals and furthermore, associations are at present working on this thought, which pledges to deal with the issue of nonappearance of radio reach, space and low web affiliation speed. By plan of this development, we can move to greener, cleaner, safer correspondence associations. The genuine thought of Li-Fi promises to handle issues, for instance, lack of radiofrequency information transmission and murders the burdens of Radio correspondence progresses. Li-Fi is the approaching and creating advancement going about as force for various other making and new turns of events/propels. Thusly, there is confirmation of progress of future employments of the Li-Fi which can be loosened up to different stages and various walks around human life.

VII. REFERENCES

- [1]. H. Haas, L. Yin, Y. Wang, and C. Chen, "What is LiFi?" *Journal of Lightwave Technology*, vol. 34, no. 6, pp. 1533–1544, 2016.
- [2]. I. Tavakkolnia, C. Chen, R. Bian, and H. Haas, "Energy-Efficient Adaptive MIMO-VLC Technique for Indoor LiFi Applications," in *25th International Conference on Telecommunication (ICT 2018)*, Saint-Malo, France, June 2018.
- [3]. S. Wu, H. Wang, and C.-H. Youn, "Visible Light Communications for 5G Wireless Networking Systems: From Fixed to Mobile Communications," *IEEE Network*, vol. 28, no. 6, pp. 41–45, 2014.
- [4]. Cisco, "Cisco Visual Networking Index: Global Mobile Data Traffic Forecast Update, 2016–2021 White Paper," white paper at Cisco.com, Mar. 2017.
- [5] A.M. Kalid, G. Cossu, R Corsini, P. Choudhury, E. Ciaramella, "1-Gb/s transmission over a phosphorescent white led by using rate-adaptive discrete Multitone Modulation" *IEEE Photonics Journal Volume: 4, Issue: 5*, pp. 1465-1473, 2012.
- [6]. G. Cossu, A. M. Khalid, P. Choudhury, R. Corsini, and E. Ciaramella, "3.4 Gbit/s visible optical wireless transmission based on RGB LED" . *Optics Express* 20 (26), pp B501-B506, December 2012.
- [7]. D. Tsonev, H. Chun, S. Rajbhandari, J.D. McKendry, S. Videv, E. Gu, "A 3-Gb/s Single-LED OFDM-Based Wireless VLC Link Using a Gallium Nitride μ LED". *IEEE Photonics Technology Letters*, volume 26 (7).
- [8]. D.Tsonev, S.Videv, H.Haas, "Towards a 100Gb/s visible light wireless access network" *Optics Express*.
- [9]. G. Cossu, A. M. Khalid, P. Choudhury, R. Corsini, and E. Ciaramella, "3.4 Gbit/s visible optical wireless transmission based on RGB LED" . *Optics Express* 20 (26), pp B501-B506, December 2012.