



# DEVELOPMENT OF HEALTH CARE MONITORING SYSTEM FOR ELDER PEOPLE USING INTERNET OF THINGS

R.Deepalakshmi

*Department of Electronics and Communication Engineering  
CARE College of Engineering, Tiruchirappalli, Tamilnadu, India*

R.Vanitha

*Department of Electronics and Communication Engineering  
CARE College of Engineering, Tiruchirappalli, Tamilnadu, India*

M.Shivashankari

*Department of Electronics and Communication Engineering  
CARE College of Engineering, Tiruchirappalli, Tamilnadu, India*

Dr.J.Jeyarani

*Department of Electronics and Communication Engineering  
CARE College of Engineering, Tiruchirappalli, Tamilnadu, India*

J.Jecintha

*Department of Electronics and Communication Engineering  
CARE College of Engineering, Tiruchirappalli, Tamilnadu, India*

**Abstract-** Conventional sensor based diagnosis in medical field requires more number of sensors and human efforts if it is processed in a large scale. It is a difficult task due to the shortage of medical professionals and system setup. To overcome this issue an IoT based health care application is proposed in the research work. The proposed system consists of the web and mobile application based on continuous wireless monitoring of patients. The objective of this paper is to implement a low-cost system and transmit the patient vital signs in emergency situations. Sensors are being used for measuring the patient vital signs by using the wireless network. The sensors data are collected and transmitted to the cloud for storage via Wi-Fi module connected with the controller. The data is processed in the cloud and feedback steps are taken on the analysed data which can be further analysed by a doctor remotely. Remote viewing reduces burden to doctors and provides the exact health status of patients. If the patient needs urgent attention then a message is sent to the doctor.

**Keywords:** Health care, Elder people, IOT, Wi-Fi Module, Sensors, Wireless Networks, Remote Monitoring

## 1. INTRODUCTION

Internet of Things (IoT) is nothing but the devices (things) communicating with each other by using the internet. IoT applications vary on a large scale. European Research Cluster on the Internet of Things classifies major IoT applications as smart buildings, smart transportation, Smart energy, smart industry, smart health and the smart city as major areas. IoT is a trendsetting innovation in which all the data from sensors is stored in the cloud where it can be easily accessed from the cloud. Sensors and actuators for gathering the data and sending across the internet are also included in this advancement. We use cloud not only to store data but also for data analysis, gathering, visualization. Such an emerging technology can be used in various IoT applications like agriculture, health, smart home etc., to make the already existing systems more efficient. The key characteristics of the cloud include on demand service provision, ubiquitous access, resource pooling and, elasticity. In India, we have 493 coalmines present. Coal is the most vital asset in the world. These petroleum products are natural assets of the earth which help create power and for some, purposes. Coal is a non-sustainable source which can't be supplanted commonly by humans, there are numerous coalmine mischances happening in the mines, and the diggers are putting their lives in hazard by working in the coal mines, even once in a while they wind up losing their lives in the coal mines which is an unfortunate part. Mainly these mishaps are happening as a direct result of the old hardware and the wired

systems, resulting in the terminate mischance's, spillage of the noxious gases in the coal mines are presenting immense dangers to the excavators inside the coalmines.

In the underground coalmines light is an essential thing to convey their work, They can't leave the mine if there is no legitimate lighting which coming about them to harm the mineworker's vision because of working under low lighting area. So to stay away from this issue we have structured the coalmine security framework. In our work, we have tackled the issues by checking every one of the information gathered by the sensors which we have utilized and the observing is finished utilizing the Thinker platform. Controlling is possible by both automatically and manually. The microcontroller here in the work we have utilized is Node MCU.

## 2. LITERATURE REVIEW

Health-care Environment has developed science and knowledge based on Wireless-Sensing node Technology oriented. Patients are facing a problematic situation of unforeseen demise due to the specific reason of heart problems and attack which is because of nonexistence of good medical maintenance to patients at the needed time. This is for specially monitoring the old age patients and informing doctors and loved ones. So we are proposing an innovative project to dodge such sudden death rates by using Patient Health Monitoring that uses sensor technology and uses internet to communicate to the loved ones in case of problems. This system uses Temperature and heartbeat sensor for tracking patient's health. Both the sensors are connected to the Arduino-Uno. To track the patient health micro-controller is in turn interfaced to a LCD display and Wi-Fi connection to send the data to the web-server (wireless sensing node). In case of any abrupt changes in patient heart-rate or body temperature alert is sent about the patient using IoT. This system also shows patients temperature and heartbeat tracked live data with timestamps over the Internet. Thus Patient health monitoring system based on IoT uses internet to effectively monitor patient health and helps the user monitoring their loved ones from work and saves lives[1].

Continuous fitness monitoring can store up to 60% of human lives through timely detection. The device is specially designed for actual time monitoring of the health parameters of the coma sufferers. It has more suitable by means of the use of GSM and IoT to recognize the status or condition of the patient. This proposed method consists of numerous smart sensors like Temperature, Heartbeat, Eye blink and SPO2 (Peripheral Capillary Oxygen Saturation) sensors for fetching the patient's body temperature, coronary heart rate, eye movement and oxygen saturation percentage of the patient. This system use ARDUINO-UNO board as a microcontroller and Cloud computing concept. Here the accelerometer sensor used to display the body movement of the coma sufferers. The patient's vital parameters are transmitted to smart telephones and laptops of the legal individual by the use of a cloud server. These records may be saved and analysed for further evaluation and selection making [2].

The design and implementation of IOT based health monitoring system which incorporates temperature and pulse rate sensors. The patient's body will be monitored continuously and the doctor can know about the patient's condition while sitting somewhere in front of a computer screen. Whenever the condition of the patient goes abnormal an alert will be sent to the doctor through the mail so that he can diagnose the problem immediately which helps to save patient's life. The main purpose of this project is to inform the doctor about the patient's health condition time to time and if any abnormality occurs, the doctor can take the best step immediately [3].

IOT is one of the booming field in forthcoming years and plays a major role in the field of health care. IOT helps in connecting the people by empowering their health and wealth in a smart way through wearable gadgets. Recent improvements in wireless sensor networks have created a new trend in internet of things. Smart health is important application in Internet of things. Patients with abnormal health conditions can be quickly monitored through smart health care system and provide a rapid solution for the patients. This type of solutions can be encountered through wearable gadgets that continuously monitor the activity and condition of the patient in a predictable method. The main aim of this work is to provide an extensive research in capturing the sensor data's, analysing the data and providing a feedback to patients based on different health parameters [4].

Internet of Things has been one of the catalysts in revolutionizing conventional healthcare services. With the growing society, traditional healthcare systems reach their capacity in providing sufficient and high-quality services. The world is facing the aging population and the inherent need for assisted-living environments for senior citizens. There is also a commitment by national healthcare organizations to increase support for personalized, integrated care to prevent and manage chronic conditions. Many applications related to In-Home Health Monitoring have been introduced over the last few decades, thanks to the advances in mobile and Internet of Things technologies and services. Such advances include improvements in optimized network architecture, indoor networks coverage, increased device reliability and performance, ultra-low device cost, low device power consumption, and improved device and network security and privacy. Current studies of in-home health monitoring systems presented many benefits including improved safety, quality of life and reduction in hospitalization and cost. However, many challenges of such a paradigm shift still exist, that need to be addressed to support scale-up and wide uptake of such systems, including technology acceptance and adoption by patients, healthcare providers and policymakers. The aim of this paper is three folds: First, review of key factors that drove the adoption and growth of the IoT-based in-home remote monitoring; Second, present the latest advances of IoT based in-home remote monitoring system architecture and key building blocks; Third, discuss future outlook and our recommendations of the in-home remote monitoring applications going forward[5].

### 3. EXISTING SYSTEM

In the existing system, we use active network technology to network various sensors to a single PMS. Patients' various critical parameters are continuously monitored via single PMS and reported to the Doctors or Nurses in attendance for timely response in case of critical situations. The sensors are attached to the body of the patients without causing any discomfort to them. In this PMS we monitor the important physical parameters like body temperature, ECG, heart beat rate and blood pressure using the sensors which are readily available. Thus, the analog values that are sensed by the different sensors are then given to a microcontroller attached to it. The microcontroller processes these analog signal values of health parameters separately and converts it to digital values using ADC converter. Now, the digitalized values from more than one microcontroller are sent

to the Central PMS. Each of the sensors attached microcontroller with a transceiver will act as a module which has its own unique ID. Each module

transmits the data wirelessly to the gateway attached to the PC of the Central PMS. The gateway is attached to the PC i.e. Central PMS which is situated in the medical center, is capable for selecting different patient IDs and allowing the gateway to receive different physical parameter values the patient specified by the ID. The software designed using Graphical User Interface (GUI) can operate on different physical parameters of each patient, consecutively with a specified time interval for each patient. At any time, any of the doctors or nurses can log on the Central PMS and check the history of the observed critical parameters of any of the patient attached to the network. In case of a critical situation which requires the immediate attention of the doctors or nurses for any of the patients, the custom software will instruct the Central PMS to enable the GSM modem to send an SMS with the patient ID. A voice call is also made to the doctors and the staffs of the hospital. The SMS also consists of a status of the patient's physical condition. With the help of the patient ID, the doctor can easily identify and attend to the patient situation

### 4. PROPOSED SYSTEM

Thing speak IoT platform and we clearly defined the derivations that mentions the correct ppm on the screen with correct calibration. We have implemented it with less cost i.e., when we are pushing the data to the cloud, no need to see the output on LCD which adds more cost to the project. When we are targeting IoT as a platform, our intension should be to present the idea on internet using the platforms like thinger.io or thing speak or Cayenne website which are beautifully designed to present the output and even able to download the dataset. When doing an experiment air quality monitoring, no need to use LPG or methane detecting sensors as it is used for Home/office safety. We have used Wi-Fi to push the data onto the cloud rather using GSM or GPRS module. The problem in another paper that cited at hasn't calibrated the sensor and not even converted the sensor output value into PPM. As per the guidelines by UN Data, 0-50 PPM is SAFE value, 51-100 is moderate as shown in figure 1. Delhi is the most polluted city in the world recorded around 250PPM. As we are using two sensors, both of them have internal heat element, it draws more power( $P=V*I$ ), so though the both sensors are turned ON, its output voltage levels varies and shows unpredictable values due to insufficient power drive. So we used a 9V battery and a 7805 family LM7805 Regulator for the CO sensor MQ7. We have used Arduino Uno Development kit that comes with ATmega328P microcontroller. In order to provide WIFI Support for it, we have used cost effective ESP-01 Wi-Fi module which helps us to connect to the Thing Speak Platform.

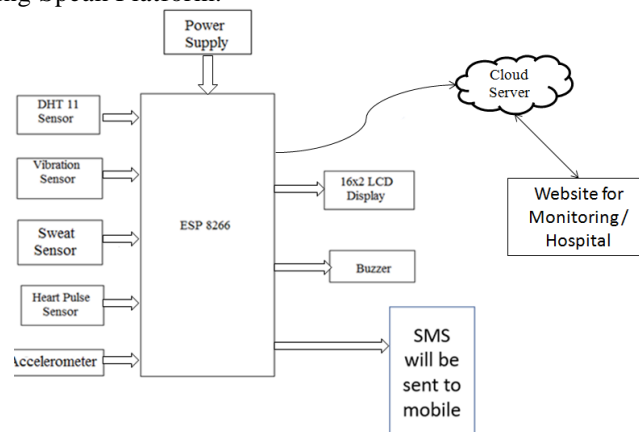

Fig 4.1 Block diagram of proposed system

### ADVANTAGES

- Better inform and monitor the impact of regulations to control air quality.
- Plan the placement of vulnerable facilities like hospitals and schools to reduce asthma in children and improve the outcome of sick patients.
- Empower city residents to make more informed decisions to limit their exposure to harmful air pollution.

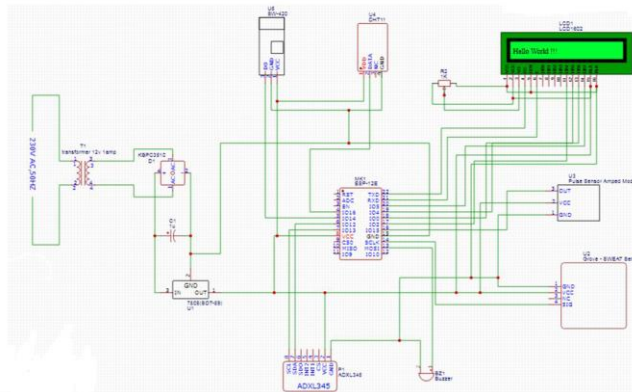

Fig 4.2 Circuit diagram of proposed system

### 5. RESULTS & CONCLUSION

All the individual modules like Heartbeat detection module, fall detection module etc. and remote viewing module gave out the intended results. The designed system modules can further be optimized and reduced to a final single circuit. More important fact that came up during project design is that all the circuit components used in the remote health detection system are available easily. With the development in the integrated circuit industry, Micro Electro Mechanical Systems (MEMs) and microcontrollers have become affordable; have increased processing speeds, miniaturized and power efficient. This has led to increased development of embedded systems that the healthcare specialists are adopting. These embedded systems have also been adopted in the Smartphone technology. And with increased internet penetration in most developing countries through mobile phones, and with use of Internet of things (IoT) will become adopted at a faster rate. The Remote Health Care system utilizes these concepts to come up with a system for better quality of life for people in society. From an engineering perspective, the project has seen concepts acquired through the computer science and embedded study period being practically applied. The Electric circuit analysis knowledge was used during design and fabrication of the individual modules. Electromagnetic fields analysis used in the wireless transmission between microcontrollers and Software programming used during programming of the microcontrollers to come up with a final finished circuit system.

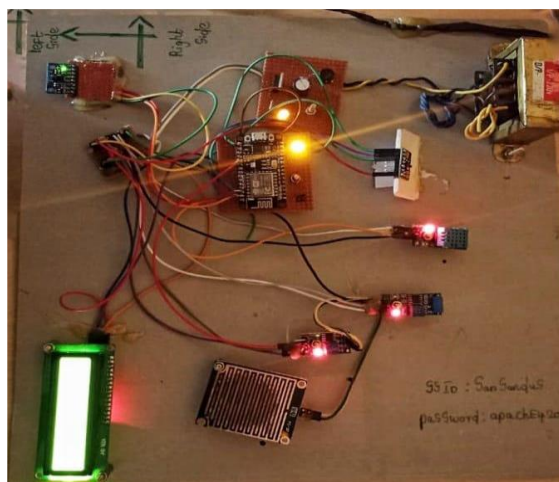

Fig 5.1 Implementation of Proposed System



Fig 5.2 Temperature and Blood pressure Monitoring



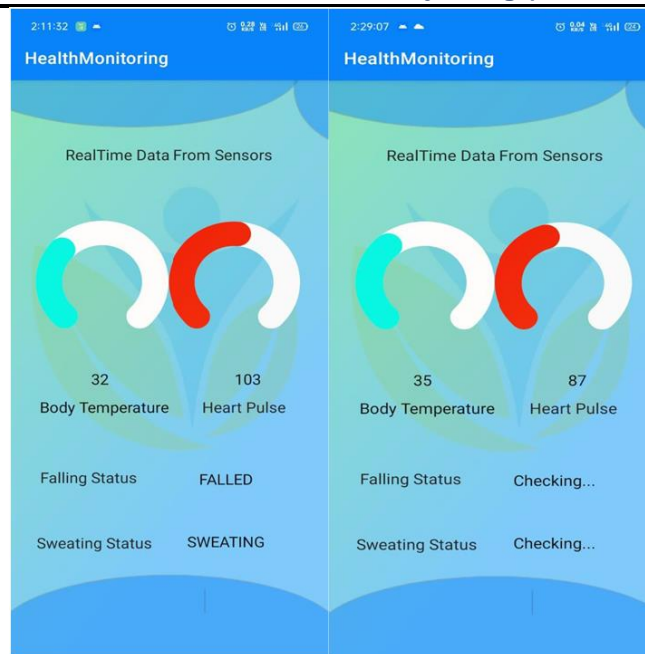

Fig 5.3 Application view of Health monitoring system

## 5. FUTURE WORK AND CONCLUSION

System we have created operates on only on the health, but our current state, we can add more health sensor devices, where each sensor can be used provide health values .All it need is more electronic sensor and modification. The following things to be done in future

1. Physiological data collection
  - a. Home Ultrasound
  - b. Brain signal monitoring
2. Remote viewing of data Problems associated with having data online. Tackle Distributed denial of service. DDOS, and Data privacy/security especially of medical systems.
3. IoT based Remote Patient Monitoring System can be enhanced to detect and collect data of several anomalies for monitoring purpose such as home ultrasound, Brain signal monitoring, Tumor detection etc.
4. More research on problems associated with having data online, data privacy as IoT is managed and run by multiple technologies and multiple vendors are involved in it. Security algorithms and certain precautions by the users will help avoid any security related threats in IoT network.
5. The interface can be designed to control which sensors can be used by consumers according to their needs.
6. Web UI can be enhanced to perform several activities which include controlling the hardware, real-time graphs, history and analysis graphs to observe anomalies etc.

## 6. REFERENCES

- [1] D. S. R. Krishnan, S. C. Gupta and T. Choudhury, "An IoT based Patient Health Monitoring System," *2018 International Conference on Advances in Computing and Communication Engineering (ICACCE)*, 2018, pp. 01-07, doi: 10.1109/ICACCE.2018.8441708.
- [2] Tamilselvi, V & Sribalaji, S & Vigneshwaran, P & Vinu, P & GeethaRamani, J, "IoT Based Health Monitoring System" 386-389. 10.1109/ICACCS48705.2020.9074192. (2020).
- [3] A.R.Kaaviyan, G.Kumaravel, M.Ranjith Kumar, Dr.Komala James, "Health Monitoring Of Patient Using Body Area Network" *IJCRT Volume 8, Issue 3 March 2020 | ISSN: 2320-2882, 2020.*
- [4] S. Ananth, P. Sathya and P. Madhan Mohan, "Smart Health Monitoring System through IOT," *2019 International Conference on Communication and Signal Processing (ICCSP)*, 2019, pp. 0968-0970, doi: 10.1109/ICCSP.2019.8697921.
- [5] N. Y. Philip, J. J. P. C. Rodrigues, H. Wang, S. J. Fong and J. Chen, "Internet of Things for In-Home Health Monitoring Systems: Current Advances, Challenges and Future Directions," in *IEEE Journal on Selected Areas in Communications*, vol. 39, no. 2, pp. 300-310, Feb. 2021, doi: 10.1109/JSAC.2020.3042421.
- [6] Z. Zhiao, Chnaowei, and z. Nakdahira, "Healthcare application based on Internet of Things," in *Proc. IEET Int. ConfE. On Technolgy. Application.*, Nov. 2013, pp. 661 662. [2] Kortoom.Y. Kaiseer, N. Fittop, and D.ramamoorthy, "Canny matters as construction brickss for application of Internet of Things," *IEE-E Interne Networks andtComput.*, vol. 17,
- [7] Z. Achmed and G. Miguel, "Assimilating Wireless Sensing Nets with Cloud& Computing," *2010 SixthIntt.Confe.Mobi.Ad-hocc Sense. Netks*, pp. 263-266, Oct. 2010.
- [8] Shahriyar, R., Bari, M.F., Kundu, G., Ahamed, S.I., Akbar, M.M.: Intelligent mobile health monitoring system (IMHMS). *Int. J. Control Autom.* 2, 13-28 (2009)
- [9] Sannino, G., Pietro, G.: An advanced mobile system for indoor patients monitoring. In: *2nd International Conference on Networking and Information Technology IPCSIT*, vol. 17, pp. 144-149 (2011)
- [10] Kaczmarek, M., Ruminski, J., Bujnowski, A.: Multimodal platform for continuous monitoring of elderly and disabled. In: *2011 Federated Conference on Computer Science and Information Systems (FedCSIS)*, pp. 393-400 (2011)

- [11] Yu, M., Rhuman, A., Naqvi, S.M., Wang, L., Chambers, J.: A posture recognition-based fall detection system for monitoring an elderly person in a smart home environment. *IEEE Trans. Inf. Technol. Biomed.* 6, 1274–1286 (2012)
- [12] Global Market Insights', 2019, [online] Available:<https://www.marketwatch.com/press-release/mhealth-market-2019-industry-analysis-size-share-growth-by-2025-global-market-insights-2019-07-29>.
- [13] Global Market Insights', 2019, [online] Available: A. Froytlog et al., "Ultra-low power wake-up radio for 5G IoT", *IEEE Commun. Mag.*, vol. 57, no. 3, pp. 111-117, Mar. 2019.
- [14] K. Guk, G. Han, J. Lim, K. Jeong, T. Kang, E. K. Lim, et al., "Evolution of wearable devices with real-time disease monitoring for personalized healthcare", *Nanomaterials*, vol. 9, no. 6, pp. 813, 2019.
- [15] S. Kitsiou, G. Paré, M. Jaana and B. Gerber, "Effectiveness of mHealth interventions for patients with diabetes: An overview of systematic reviews", *PLoS ONE*, vol. 12, no. 3, Mar. 2017.
- [16] The Rise of Remote Patient Monitoring, May 2019, [online] Available:<https://thejournalofmhealth.com/the-rise-of-remote-patient-monitoring/>.
- [17] I. Chouvarda, N. Philip, P. Natsiavas, V. Kilintzis, R. Kayyali and D. Sobnath, "WELCOME—Innovative integrated care platform using wearable sensing and smart cloud computing for COPD patients with comorbidities", *Proc. IEEE Eng. Med. Biol. Soc.*, pp. 3180-3183, Aug. 2014.
- [18] InCASA, Oct. 2020, [online] Available: <http://www.incasa-project.eu>.
- [19] Ebbits, Oct. 2020, [online] Available: <http://www.ebbits-project.eu>.
- [20] MASSIF, Oct. 2020, [online] Available: <http://www.massif-project>.
- [21] E. Kaimakamis et al., "Experience of using the welcome remote monitoring system on patients with COPD and comorbidities", *Proc. Int. Conf. Biomed. Health Inform. (ICBHI)*, vol. 66, pp. 97-102, 2017.
- [22] R. Zgheib et al., "Semantic middleware architectures for IoT healthcare applications" in *Enhanced Living Environments*, Cham, Switzerland:Springer, vol. 11369, 2019.
- [23] J. Jorge Rodrigues Barata, R. Munoz, R. D. De Carvalho Silva, J. J. P. C. Rodrigues and V. Hugo C. De Albuquerque, "Internet of Things based on electronic and mobile health systems for blood glucose continuous monitoring and management", *IEEE Access*, vol. 7, pp. 175116-175125, Dec. 2019.
- [24] M. A. A. da Cruz, J. J. P. C. Rodrigues, J. Al-Muhtadi, V. V. Korotaev and V. H. C. de Albuquerque, "A reference model for Internet of Things middleware", *IEEE Internet Things J.*, vol. 5, no. 2, pp. 871-883, Apr. 2018.
- [25] A. Saboor, R. Ahmad, W. Ahmed, A. K. Kiani, Y. L. Moullec and M. M. Alam, "On research challenges in hybrid medium-access control protocols for IEEE 802.15. 6 WBANs", *IEEE Sensors J.*, vol. 19, no. 19, pp. 8543-8555, Oct. 2019.
- [26] Saha, J., Saha, A. K., Chatterjee, A., Agrawal, S., Saha, A., Kar, A., Saha, H. N., Advanced IOT based combined remote health monitoring, home automation and alarm system. In *Computing and Communication Workshop and Conference*, IEEE 8th Annual, 2018.
- [27] Kalid, N., Zaidan, A. A., Zaidan, B. B., Salman, O. H., Hashim, M., Muzammil, H., Based Real Time Remote Health Monitoring Systems: A Review on Patients Prioritization and Related "Big Data" Using Body Sensors information and Communication Technology, *Journal of medical systems*, 2018.