



Generation of Power from Bicycle Pedalling

R Divya*1, Preksha Prakash *2, Samreen Kausar*3, Shilpa A*4, Sudha M S

Sapthagiri college of Engineering, Bengaluru-560057

(Affiliated to Visvesvaraya Technological University)

Abstract: Sustainable energy is produced using resources that won't endanger the environment or the energy demands of future generations. It is discovered how simple it is to generate modest amounts of power simply riding a bicycle. A battery is used to power a bicycle. A technique for converting mechanical energy from the pedal to electrical energy can be provided by the electric bike motor that is connected to the bicycle pedal. For using it to run any appliance conversion of this dc power to ac power is essential which can be done by using an inverter. Output of the motor that serves as a generator depends on the pedaling speed. In order to ascertain the behavior of the electrical output is varied, it should be taken into consideration the speed developed by the user. It can also be implemented on a larger scale for bigger vehicles. This is more eco-friendly and also convenient.

Keywords: Bicycle, battery, electric bike, motor, inverter, generator.

I. INTRODUCTION

With the growing population, the demand of electricity is very high and the scarcity of electricity is an upcoming problem. This paper focuses on producing power with the least amount of resources and at the lowest possible cost. This mostly generates electrical power. It is powered by a manual mechanism. There is a dual purpose to this whole project and that is generation of power and in turn riding a bicycle which can be used to be for transportation or just to be physically fit. The goal of this paper is to make it possible for everyone to engage with a power generation system and eventually understand how easy measures may be made to reduce our carbon footprints on the environment and cut their energy costs.

A particle or an item that is in motion possesses a sort of energy called kinetic energy. When an item is subjected to work that involves the transfer of energy by the application of a net force, the object accelerates and consequently obtains kinetic energy. Here, the kinetic energy of the pedalling is finally transformed into electrical energy.

The energy produced by the rider while pedalling may be captured by an electric bike motor. Direct or alternating current can be produced by generators. With this power, small gadgets like mobile phones and laptops may be charged. Bikes, automobiles, etc. may all be utilised with this technique. Additionally, the amount of energy generated throughout this time is flawless. This research is being done to learn more about a bicycle-powered generator of energy and its viability.

II. LITERATURE SURVEY

B.Sneha et.al. [1] introduced the technique describing a simple method of producing electricity at low levels by utilising a bicycle pedal. For running of appliances the dc power was converted to ac power by using inverter. Output of the dynamo or generator depends on the pedalling speed.

Rajesh Kannan et.al. [2] used the technique of conversion of mechanical to electrical energy utilising an alternator or dynamo. Mobile phones or other tiny lightning-related gadgets can be charged using the output electric energy produced. **Rajneesh Suhalkal et.al. [3]** designed the bicycle which generates the electrical power based on the pedalling speed of the pedlar. Using MATLAB Simulink, a model of the pedal power generator with a permanent magnet synchronous generator was constructed.

Michael Mazga et.al. [4] created a pedal-powered generator with a lighting system and tested. The car alternator was used to generate the power. **Swathi M et.al. [5]** focused on the production of electrical power utilising various generator types, storage, and its use. The output power and efficiency of the BLDC and PMDC motor was compared. **Shwetha Matey et.al. [6]** proposed electric power is used to move the electric bike. **Willett Kempton et.al. [7]** proposed Electric utilities will value electric-drive cars as a source of power, regardless of whether they are powered by batteries, liquid, or gaseous fuels, or both. **A B Deepika et.al. [8]** proposed with the development of technology Due to their effective functioning, electric and hybrid cars are receiving greater attention today. Generation is started by the connecting generator to the rear wheels. This method is referred to as self-generation.

Kumud Pant et.al. [9] proposes Electricity is essential to the nation's economic growth. A novel idea called flywheel energy storage is being utilised to get around the drawbacks of irregular energy supply. **Rathnavel P et.al.[10]** proposes the using a novel method that combines a thermoelectric generator and a piezoelectric generator. Based on the thermoelectric effect, the thermoelectric generator produces electricity in response to applied temperature differences. **Ahmad Muzammil et.al. [11]** suggests that because they are cleaner than traditional vehicles, electric vehicles have been considered a form of transportation for the future. **M I Anju et.al. [12]** proposes A motor generator set is a hybrid device made up of a motor and a generator that are mechanically connected by a shared shaft. **Siting Chang et.al. [13]** extended the issue by considering the best places for charging stations that employ inductive charging technology.

Shreemoy Kumar Nayak et.al. [14] developed a system that transforms kinetic energy back into potential energy and stores it for use at a later time. **Vaibhav Barot et.al. [15]** explained how to make use of the energy lost when a vehicle crosses a speed breaker in the form of jerking pressure. **J Florez et.al. [16]** outlines the architecture of a device that produces electricity utilising the effort put forward by a team of people riding a spinning cycle. **Shubham U et.al. [17]** designed a system that overcomes all the drawback of ebike. This sort of bike doesn't require any external energy, such as petrol or external battery charging. **Farbod Khoshnoud et.al. [18]** worries about the car suspension systems' ability to capture energy. Regarding applications of self-powered vibration control, the idea of self-powered actuation utilising the energy captured via suspension is considered.

III. METHODOLOGY

This work focuses on generating electricity by pedalling the bicycle. The block diagram of the work is shown in Figure 1. The electric bicycle is to be developed and it runs with the help of the battery and the electricity is being generated from Bicycle pedalling.

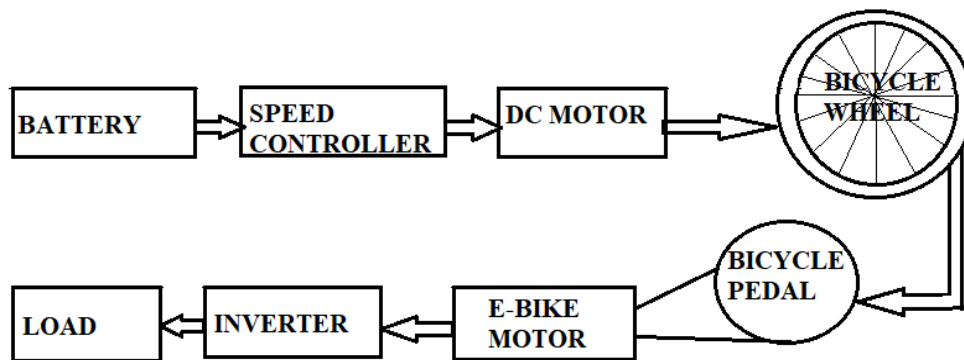

Figure 1 Overall Block diagram of generation of power from Bicycle pedalling.

The Chloride Exide Safe power Battery connected to a speed controller and the speed controller is in turn connected to the DC motor. The speed controller is used to boost the motor's speed. Due to the DC motor's mechanism, which transforms electrical energy into mechanical energy, the wheel with the DC motor attached turns as soon as the motor is turned on.

The 12V DC input from the battery serves as the speed controller's input. The ends of the DC motor are linked to the speed controller's output. By adjusting the voltage that is delivered to an electric motor, a motor speed controller just controls its speed and direction. Using a method known as pulse width modulation (PWM), the speed controller turns the battery connected to the motor on and off about 20,000 times per second.

The speed of a DC motor (N) is given by,

$N = K (V - I_a R_a) / \phi$ Where, K is a constant, V is the voltage, I_a is the current generated, R_a is the resistance, ϕ is the phase .

As the Bicycle runs the electrical energy is to be generated from the moving Bicycle. This phenomenon is fulfilled by the electric bike motor. The e-bike bike motor practically can generate electricity by the kinetic energy that is being possessed.

An electric motor generates torque that spins a shaft that's connected to a chain ring. The motor is therefore supplementing your pedalling power within the bike's chain drive, rather than adding an additional power source. The motor is a 24V 250W motor that's generates electricity and gives the output voltage of 12V.

The Figure.2 gives the cross sectional view of e-bike motor.

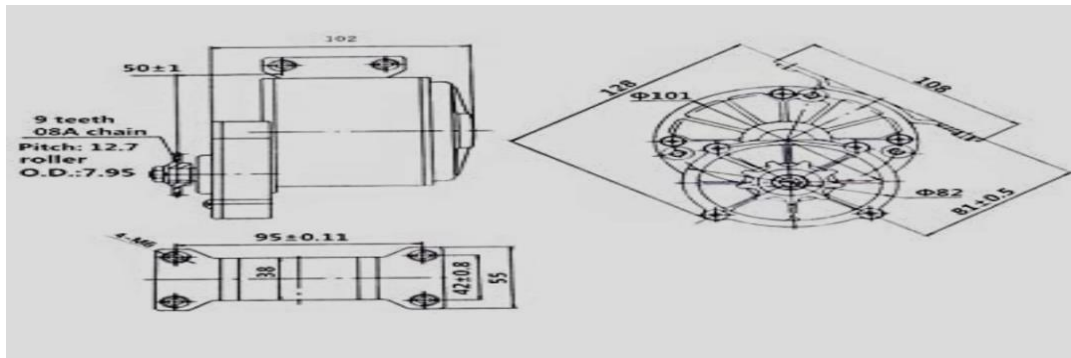

Figure 2 Cross sectional view of E-bike motor

The following step is to switch from 12V DC to 220V AC. For this, an inverter that works best with this model must be designed. The suggested solution employs a 500 watt inverter to convert from 12 volts dc to 220 volts ac. The type of inverter employed in this instance is an automobile inverter, as seen in Figure 3, which converts 12 V of input power into 220 V of output voltage.

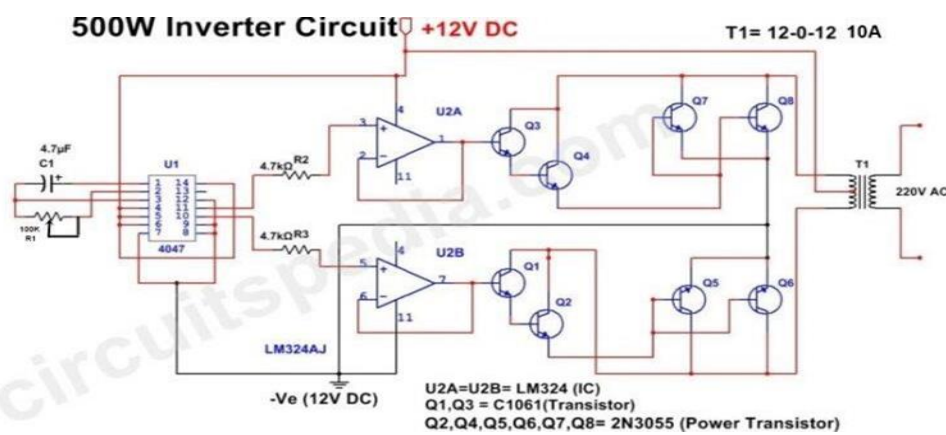

Figure 3 Represents the Inverter circuit diagram

The output generated the inverter is given to various loads and can be used to access any electric appliances. The power generated can be also used to charge the discharging battery. The Inverter also has a 5V USB port that can be used for other purposes.

RESULT

The DC motor used here is a 775 DC motor with a 12V DC supply that gives the Rpm value of 30 rotations per minute.

The distance covered by the cycle is calculated by,

Circumference of the wheel * Rpm

Hence for 30Rpm, Distance = $2 * \pi * r * 30$ [r = 0.3m]

Distance = 54.54 m/ min, therefore 3.3KM/ Hour

As the Bicycle is in motion, it gives out electrical energy with its own kinetic energy. The Figure.4 indicates the electricity obtained from the moving Bicycle pedal and rigged up circuit.

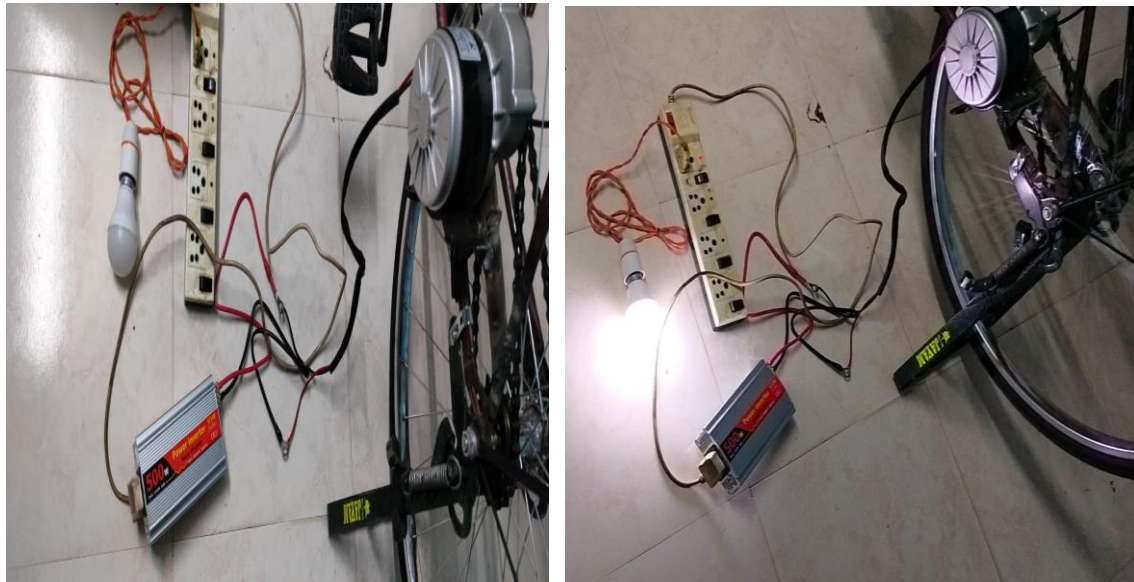

Figure 4 Represents the electricity obtained from Bicycle pedalling

It is proven that the motor can be practically used to convert the mechanical energy to electrical energy. It is concluded that a voltage of 220V AC is obtained from the mechanical energy possessed in the moving Bicycle and the obtained power is being used to access various electric appliances such as a 220V bulb, 5V mobile battery charges, etc.

The future enhancement of the developed work is that it is very easy to install, hence it can be further used in any kind of vehicles in any means of transportation.

This product can be used by anyone, and it does not effect the environment in any ways.

CONCLUSION

At a time when the global energy issue is looming large, one must consider alternate renewable energy sources. In this study, a different method of producing energy is given. A modest amount of power may be produced from the spinning energy of the bicycle pedal. It is a helpful device in areas with a limitation of electricity and is inexpensive and simple to maintain. Additionally, pedalling is a great workout that helps us stay fit. Future development of this model to include motorcycles and other vehicles, such as automobiles, has a lot of potential. In fact, some prototype models incorporating cars have already been created to expand the scope of this idea.

REFERENCES

- [1] B.Sneha, Dr.M.Damodar Reddy, "Generation of Power from Bicycle Pedal" *International Journal of Advanced Research in Electrical, Electronics and Instrumentation Engineering*, ISSN : 2320 – 3765, Vol. 4, Issue 10, pp. 8429-8434, October 2015.
- [2] Rajesh Kannan, Meggalingam, Pranay Sreedhara, Vriliyara, Raghavendra Murali Prabhu, Rocky Katoth, "Pedal Powered Generation ," *International journal of Applied Engineering Research*, ISSN: 0973-4562 ,VOL.7 ,No.11, pp. 1-5, 2012.
- [3] Rajneesh Suhalka1, Mahesh Chand Khandelwal, Krishna Kant Sharma, Abhishek Sanghi, "Generation of electrical power using bicycle pedal," *International journal of recent research and review*, ISSN : 2277-8322, Vol. 7, Issue 2, pp. 63- 67, June 2014.
- [4] Michael Mazga Ronnie Sabavalla, Ravi Kuchimanchi, "Pedal Powered electricity Generator" pp. 1-7, July 2001.

- [5] Swathi.M. Mudaliar, Anagha.R.Soman, "Electrical Power Generation Harnessing Human Energy and its Analysis" 2015 International Conference on Energy Systems and Applications (ICESA 2015) 978-1-4673-6817-9/15, pp. 333-337, 2015.
- [6] Shweta Matey, Deep R Prajapati, Kunjan Shinde, Abhishek Mhaske and Aniket Prabhu, "Design and Fabrication of Electric Bike", International Journal of Mechanical Engineering and Technology (IJMET), ISSN: 0976-6340, Volume- 8, Issue-3, pp. 245–253 , March 2017.
- [7] Willett Kempton and Steven E. Letendre – "Electric vehicles as a new power source for electric utilities" International Research Journal of Engineering and Technology (IRJET), e-ISSN: 2378-0064, p-ISSN: 2245-2345, Volume 2, Issue 4, pp-2425-2430, Jun-2018.
- [8] A.B.Deepika, S.Nandhini, R.Rajalakshmi, Ms.D.Shobana – "Power production in electric vehicle using self-generation and regeneration" International Research Journal of Engineering and Technology (IRJET), e-ISSN: 2395-0056, p-ISSN: 2395-0072, Volume 4, Issue 3, pp-2868-2871, Mar 2017.
- [9] Kumud Pant, Jyoti Mehra, Ketan Naula, Sunil Singh and Mr. Ambedkar Rai "Electricity Generation using Flywheel" International Journal on Emerging Technologies, ISSN: 0975-8364(Print), ISSN: 2249-3255(Online), Volume 8, Issue 1, pp-582-584, 2017
- [10] Rathnavel P, Baldwin Immanuel, Rayavel P – "Road Tyre Friction Used to Generation of Electrification"- International Journal of Engineering and Advanced Technology (IJEAT), ISSN: 2249-8959, Volume 9, Issue 2, pp-4112-4117, December-2019.
- [11] Ahmad Muzammil Idrisa , Ahmad Fakrul Ramlia , Nor Aini Burokb , Nur Husnina Mohd Nabilb , Zarina Ab Muisa , Ho Wai Shina "The Integration of Electric Vehicle with Power Generation Sector" A Scenario Analysis Based on Supply and Demand in Malaysia- ICCSE, volume 19 , pp-1687-1692, 2018
- [12] M.I. Anju , S. Jagadees, M. Meganathan, V. Tamilselvan, "Hybrid Power Generation Using Car Wheels" International Journal of Advanced Research in Electrical, Electronics and Instrumentation Engineering ISSN: 2320-3765(Print), ISSN: 2278-8875(Online) Volume 6, Issue 3, pp-1660-1664, March 2017.
- [13] Siting Chang, Hongyang Li, Klara Nahrsted "Charging Facility Planning for Electric Vehicles" Department of Computer Science, University of Illinois at Urbana-Champaign IEEE , ISSN: 4799-6075, Volume-1, Issue-14, pp-978-984, 2014.
- [14] Shreemoy Kumar Nayak- "Design of kinetic energy recovery system for bicycle" International Research Journal of Engineering and Technology (IRJET) ISSN: 2278-0181, Volume-9, Issue-7, pp-1178-1182, July 2020.
- [15] Vaibhav Barot , Arpen Kadia , Chintan Rabari ,Akshay Patel ,Jigar Patel and Mr. Viranchi- "Power generation using kinetic energy of vehicles" International Journal of Mechanical Engineering and Technology (IJMET), ISSN: 4325-8340, Volume-1, Issue-4, pp. 6598–6604 , September 2017
- [16] J Flórez, C Núñez , G Osmal and G Ordóñez, " Design of energy generation system by using spinning bike" The International Congress of Mechanical Engineering and Agricultural Sciences, 012006 volume-1, Issue-5, pp-362-364, 2014.
- [17] Shubham U. Tayde, Neha W. Makode, Umesh M. Laybar, Prof. Bhushan S. Rakhonde – "Self power generation electrical bicycle" - International Research Journal of Engineering and Technology (IRJET) e-ISSN:2395-0056, Volume-4, Issue-1, pp-879-882, Jan 2017
- [18] Farbod Khoshnoud, Yuchi Zhang, Ray Shimura, Amir Shahba, Guangming Jin, Georgios Pissanidis, Yong K. Chen, and Clarence W. De Silva, Fellow, "Energy Regeneration From Suspension Dynamic Modes and Self-Powered Actuation" IEEE Trans. on Industry Applications, no. 4, Volume-5, IA-24, pp-436-439, 2015.