



BECKON ORIENTED COUNTER UAS ROBOT

¹ Prutha G, ² Aishwarys S, ³ B Pavan, ⁴ Pooja H Patel, ⁵ Sai Vivek Y

¹ Assistant Professor, ² student, ³ student, ⁴ student, ⁵ student

¹Electrical and Electronics Engineering Department,

¹RajaRajeswari College of Engineering, Bengaluru, India

Abstract : Proliferation of Unmanned Aerial Systems (UAS), commonly known as drones, has introduced significant challenges to national security, critical infrastructure, and defense operations.

The counter-UAS system operates seamlessly across various military, governmental, and civilian sectors, offering scalability to address both large and small drone threats. Utilizing advanced real-time tracking capabilities, it identifies, categorizes, and engages drones autonomously, enhancing security while minimizing reliance on human intervention. Integration with radar, optical sensors, and artificial intelligence enables precise threat detection and adaptive responses tailored to diverse operational scenarios. Modular architecture ensures compatibility with existing defense infrastructures, facilitating deployment in both urban and remote environments. By delivering a robust, efficient, and reliable solution, the system envisions a significant reduction in UAS threats, safeguarding critical assets and addressing one of modern defense's most pressing challenges with unparalleled versatility and performance.

Keywords— Unmanned Aerial Systems (UAS), Defense Operations, Drone Neutralization, Signal Jamming

I. INTRODUCTION

Unmanned aerial systems have become a global challenge due to their rapid adoption across various domains. While drones bring numerous benefits, they are increasingly misused for malicious purposes, leading to severe security concerns worldwide. Terrorist organizations and non-state actors employ drones for reconnaissance, smuggling, and even attacks on critical infrastructure. Urban areas, airports, and military zones face significant risks from unauthorized aerial activities. The proliferation of drone technology has created vulnerabilities in conflict zones, where weaponized drones and swarm tactics are deployed to exploit conventional defenses.

Unauthorized surveillance, smuggling, and airspace violations are frequent problems linked to drones. Privacy violations have become a growing concern as drones are used to gather sensitive data without consent. Many regions lack adequate laws and enforcement capabilities, making it challenging to control misuse. AI-powered drones and autonomous systems are complicating detection and mitigation further, demanding advanced countermeasures to ensure security across diverse environments.

Additionally, drones have contributed to an asymmetric shift in modern warfare, providing low-cost yet highly effective tools for adversaries. Their ability to evade traditional defense mechanisms has emphasized the urgent need for specialized counter-drone solutions. Critical civilian infrastructure, including power plants and communication networks, remains at risk from targeted drone attacks, highlighting the need for proactive measures to mitigate these growing threats.

II. BLOCK DIAGRAM

This block diagram illustrates a counter-UAS system for defense applications, showcasing how various components work together to detect and neutralize drone threats. The **microcontroller** acts as the central processing unit, managing data flow and coordinating actions among connected components. The **power supply** provides energy to all components, ensuring smooth operation. **Radio TX/RX** handles signal transmission (TX) and reception (RX), enabling remote communication with external systems, while the **Wi-Fi module** facilitates wireless communication with a main control room for monitoring and system control. An **ESP32 camera** captures images or video, providing visual data to the microcontroller for drone detection. The system identifies unauthorized drones using inputs from the camera and other sensors in the **drone detection** module. **Servo motors** control the movement of mechanical parts, such as aiming or rotating mechanisms, in response to detected threats. A **gyroscope** supplies orientation and stability data to maintain accuracy during operations, while the **motor** drives mechanical actions, such as positioning or launching countermeasures. The **main control room** serves as the command center where operators monitor system activities and issue commands. In summary, this counter-UAS system integrates detection, communication, motion control, and stability systems to efficiently counter drone threats.

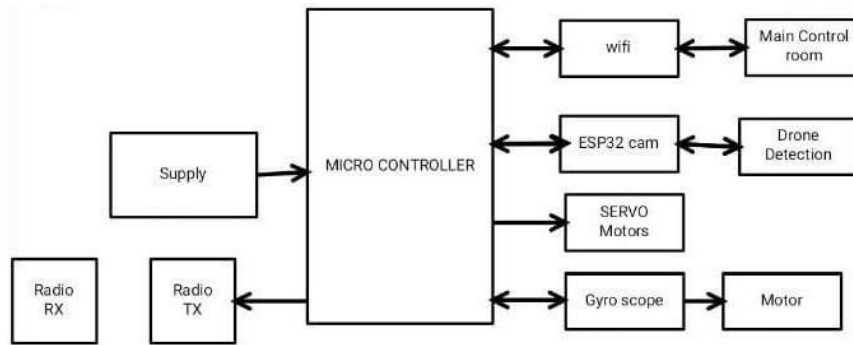

III. METHODOLOGY

The system identifies unmanned aerial systems (UAS) using live footage from a Pi Camera connected to a Raspberry Pi, which continuously scans the surrounding airspace. Pre-trained convolutional neural networks (CNNs) are employed to recognize and categorize objects as UAS, triggering alerts for operator verification. Real-time processing enables quick responses to detected threats. For gesture-based interaction, a lightweight sensor glove equipped with a gyroscope is worn by operators. The mechanism interprets gestures, such as pointing or swiping, into commands, which are transmitted to the central unit via RF modules for seamless communication.

Once a drone threat is verified, the interception mechanism is activated to capture or disrupt the UAS. The appendage rapidly deploys, enabling safe recovery of the drone for reuse or forensic investigation, thanks to its mechanical design, which minimizes the risk of damage. If interception is not feasible, the jammer module is employed to disrupt the drone's navigation and communication systems. Using directional antennas, the module precisely targets the jamming signal to minimize collateral interference. This multi-faceted approach ensures effective and efficient countermeasures against drone threats.

IV. RESULT

The system relies on various components to detect and neutralize drones effectively. It integrates detection systems such as radar, electro-optical (EO) sensors, infrared (IR) cameras, and radio frequency (RF) scanners. These components work in unison to scan the airspace and identify drones based on movement, size, and emitted RF signals. Once detected, AI algorithms process this data to classify the object as a potential threat, distinguishing drones from non-threatening objects like birds or other wildlife.

After confirming a drone's presence, the system classifies and tracks the target. AI algorithms assess the threat by analyzing parameters such as the drone's flight path, size, and communication signals. If identified as a hostile drone, operators are alerted, and precise tracking begins. The system locks onto the target, ensuring continuous tracking even if the drone attempts evasive maneuvers. Real-time data transmission to operators allows them to monitor the drone's behavior and position accurately.

In the neutralization phase, the system first deploys electronic countermeasures (ECM), which jam or spoof the drone's GPS and communication signals, disrupting control links and causing it to lose navigation or communication. If ECM fails, the system transitions to kinetic neutralization, employing tools such as nets, projectile launchers, or smaller defensive drones to physically intercept and disable the drone. For advanced threats, directed energy weapons like lasers or microwave systems target the drone's electronic components, disabling it without causing physical damage to surrounding infrastructure.

Once the drone is neutralized, the system confirms it has been disabled and continues monitoring the area to ensure no additional threats emerge. This integrated approach, combining advanced detection and neutralization components, provides effective protection against drone-based threats.

V. CONCLUSION

In conclusion, the counter-UAS system provides an effective, multi-layered solution for detecting and neutralizing drone threats by utilizing advanced detection technologies such as radar, EO/IR sensors, and RF scanners, along with electronic countermeasures, kinetic action, and directed energy weapons for precise responses. This system enhances security across military, infrastructure, and other critical applications. Looking ahead, its future scope includes integrating more advanced AI algorithms for faster threat identification, developing smaller and portable counter-UAS units through miniaturization, and improving directed energy weapons for greater efficiency. Collaborative defense networks could further expand its coverage, offering a comprehensive and adaptive defense strategy against evolving drone threats.

REFERENCES

- [1] Lindberg and H. K. H. Lee, "ERRORS OF UAV AUTONOMOUS LANDING SYSTEM FOR DIFFERENT RADIO BEACON CONFIGURATIONS," *J. Comput. Graph. Statist.*, vol. 24, no. 2, pp. 379–393, Jun. 2015,
- [2] B. Rieder, *Engines of Order: AUTONOMOUS WEAPONS AND STABILITY*. Press, 2020.
- [3] Boglaev, "AN EFFECTIVE ANTI-DRONE SYSTEM FOR INDIA'S ARMED FORCES," *J. Comput. Math.*, vol. 34, no. 3, pp. 262–284, May 2016,
- [4] Apratim Sharma, "COUNTER-UNMANNED AIRCRAFT SYSTEMS (C-UAS) FUTURE OF WARFARE," *J. Comput. Math.*, Vol. 16, No. 4, October–December 2022